

# A430A/B

KROKODILLENRUG  
DOS DE CROCODILE  
CROCODILE BACK  
KROKODILLRÜCKEN  
COCODRILLO  
SCHIENA DEL COCCODRILLO

## Montagehandleiding Notice de montage Assembling manual Montageanleitung Instrucciones para el montaje Istruzioni di installazione

Leeftijd  
Age group  
Age / Alter  
Edad / Età  
2 - 6

EUROPLAY nv  
Eegene 9  
B-9200 DENDERMONDE  
tel. 32.52.22 66 22  
fax.32.52.22 67 22  
www.europlay.eu

Dat.: 13/07/2021

Rev.: -

Page: 1/3

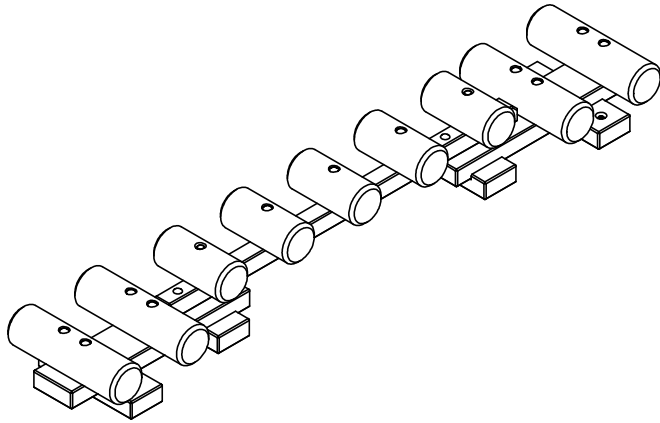

±40kg

VALHOOGTE / HAUTEUR DE CHUTE /  
FALL HEIGHT / FALLHÖHE/  
ALTURA DE CAÍDA / ALTEZZA DI CADUTA

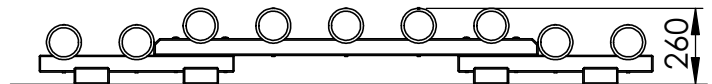
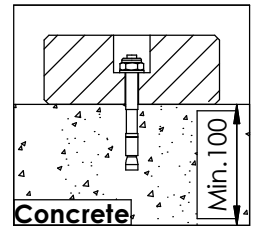

Groundlevel

VEILIGHEIDSAFSTAND / ESPACE DE CHUTE / SAFETY AREA /  
SICHERHEITSAFSTAND / ZONA DE SEGURIDAD / DISTANZA DI SICUREZZA

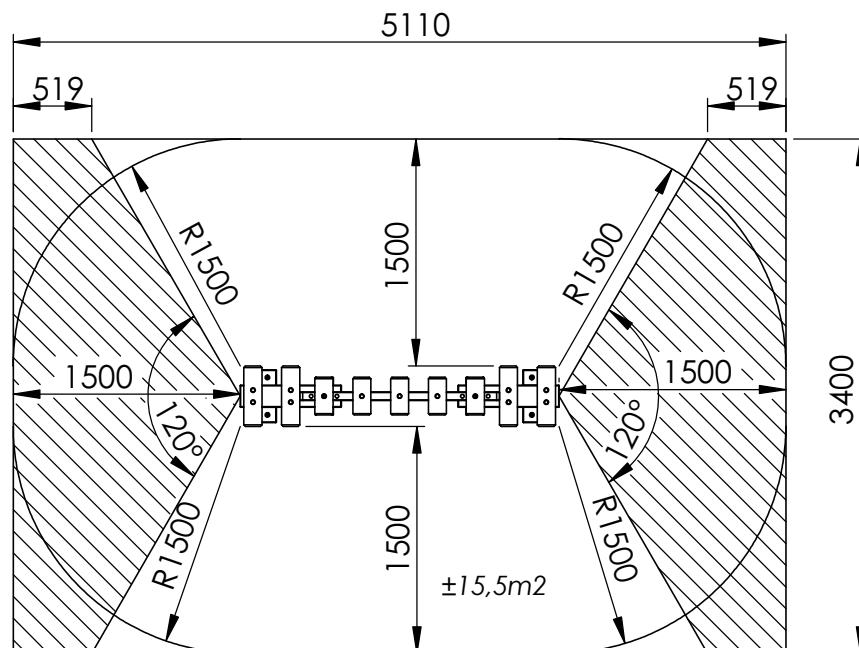

AFMETINGEN  
DIMENSIONS  
MASSE  
DIMENSIONES  
DIMENSIONI  
L: 2,1m  
Br: 0,4m  
H: 0,3m

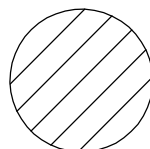

Samenvoegingszone avonturenpad  
Zone de liaison parcours d'aventures  
Verbindungsfeld survival parcours  
Linking zone adventure path  
Zona de conexión recorrido aventurero  
Zona di allineamento percorso d'avventura



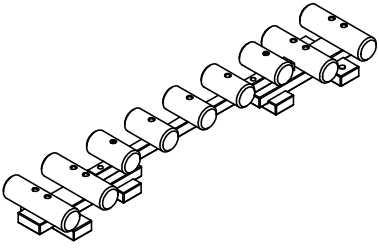

±17,5m<sup>2</sup>

**Benodigdheden - Liste des pièces - Materials - Benötigtes - Accesorios - Requisiti**

A430-As-Krokodillenrug-01

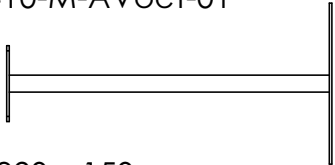

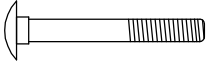
2100 x 400 x 261 37,71kg

<b>A430A</b>		<b>A430B</b>	
2x A410-M-AVoet-01		4x M10x115	
645 x 320 x 150	2.72kg		
4x M10x55			
4x M10			
4x M10			

①

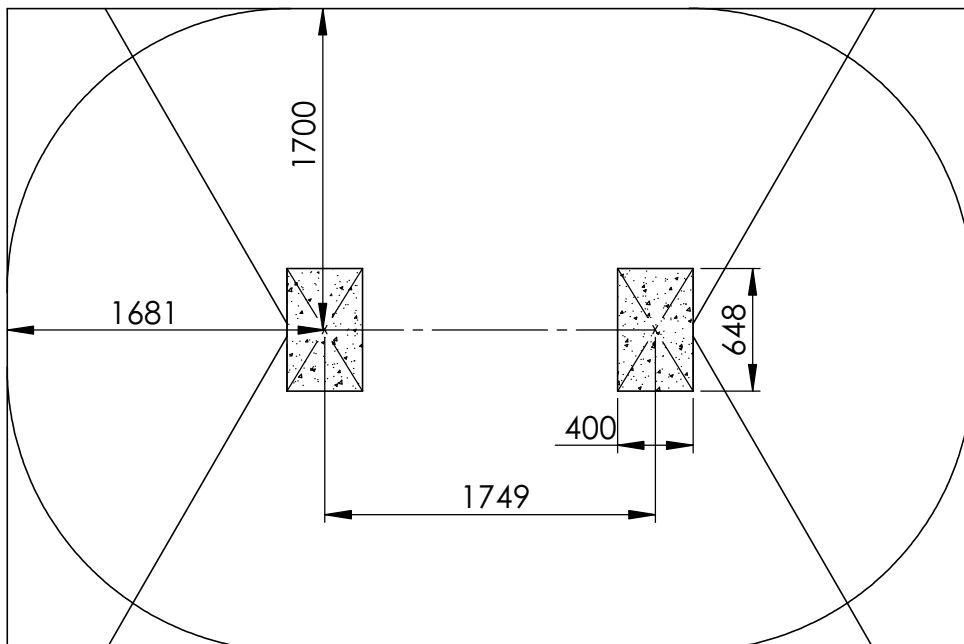

**A430A**

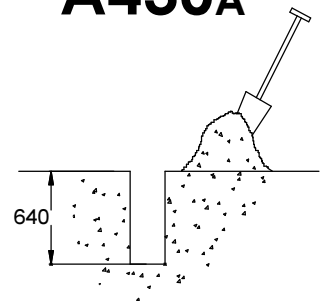

**A430B**

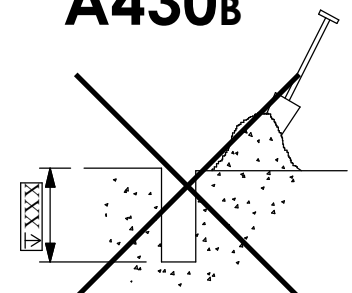

②

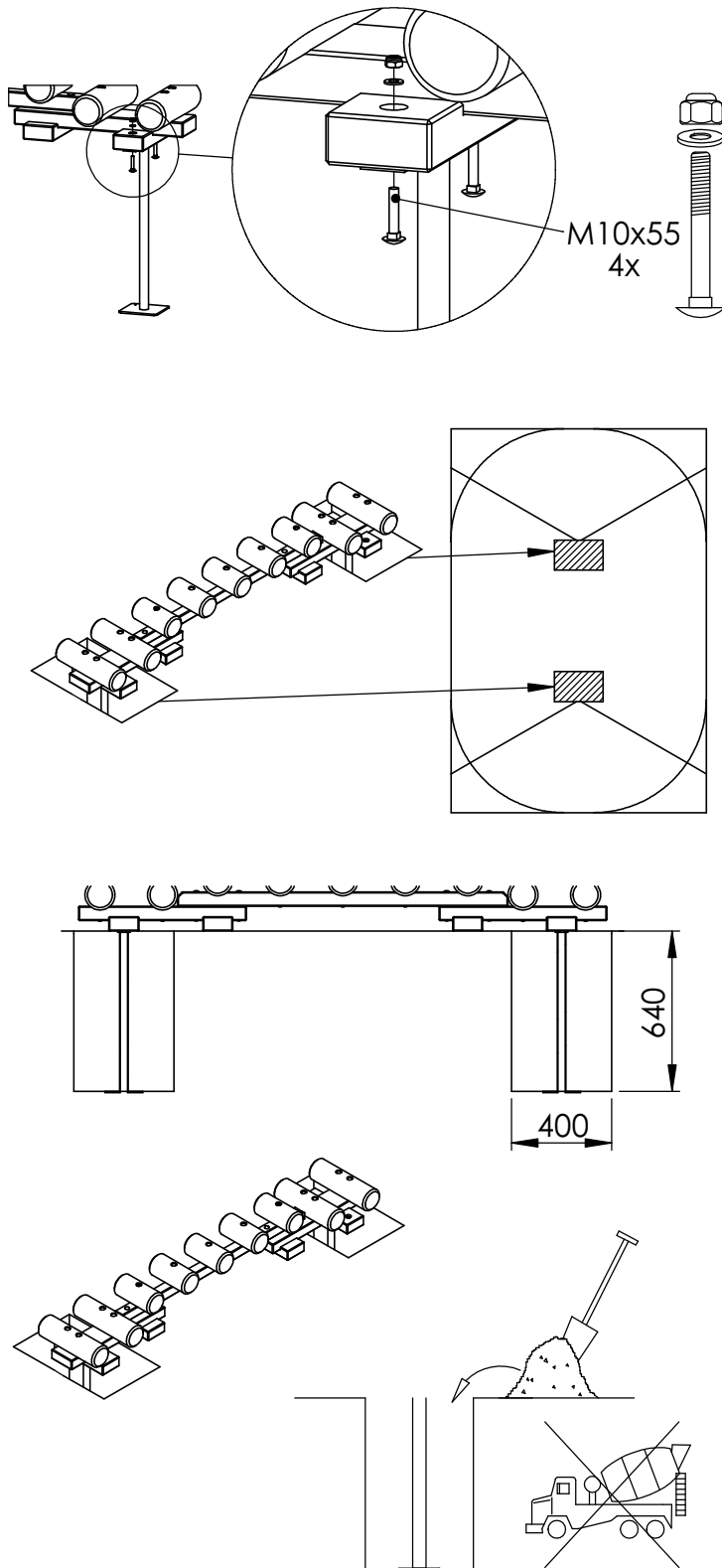
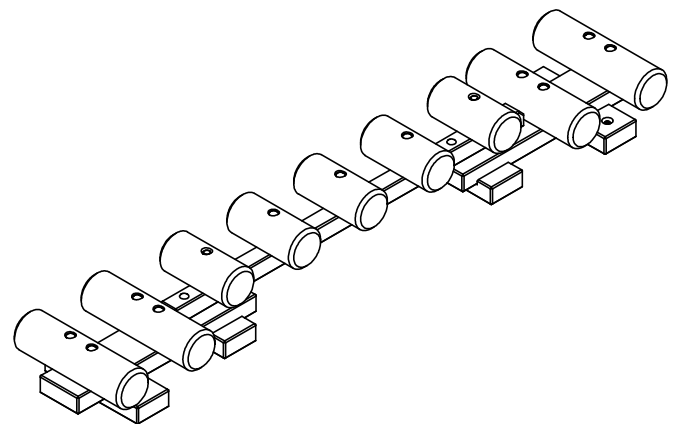
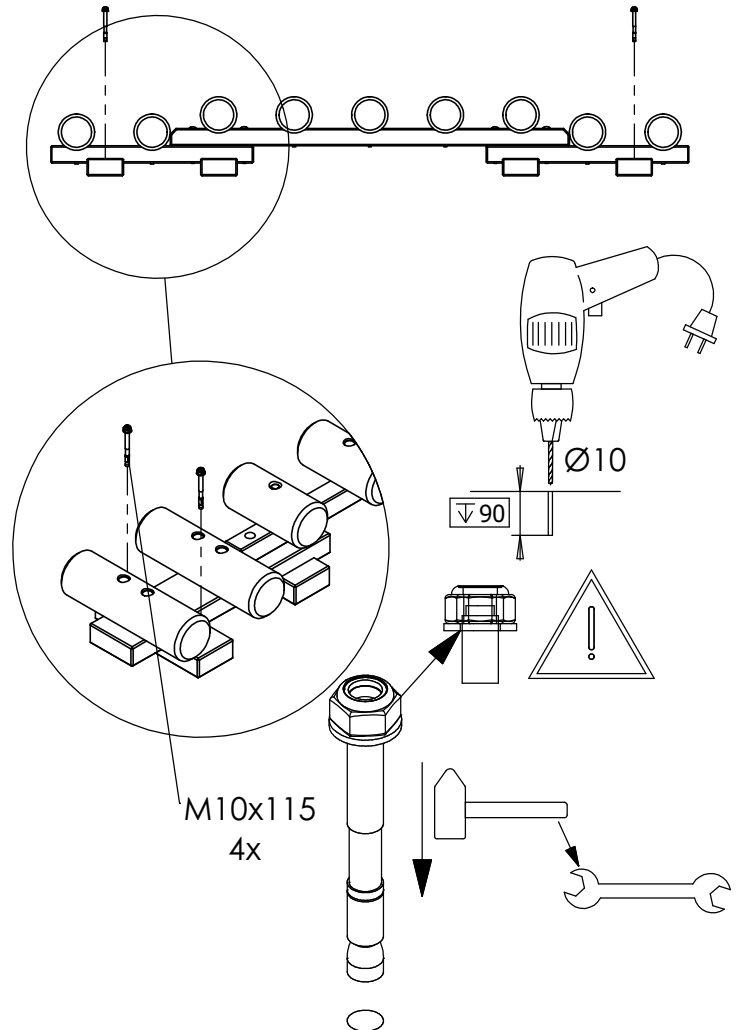
**A430A****A430B**

④

Bij droog weer moeten alle bouten en schroeven opnieuw aangespannen worden.  
Par temps sec il faut resserrer régulièrement toute la visserie.  
By dry and warm weather check the tightness of all bolts and screws.  
Bei trockenem Wetter müssen alle Schrauben und Bolzen aufs neue angespannt werden.  
Para el tiempo seco, se necesita cerrar o ajustar los tornillos y tuercas.  
Con tempo asciutto, tutti i bulloni e le viti devono essere avvitate nuovamente.