

P580

SPROOKJESHOEK
LE COIN DES SORCIERS
STORY CORNER
MÄRCHENECKE
CUENTA CUENTOS
ANGOLO DELLE FIABE

Montagehandleiding
Notice de montage
Assembling manual
Montageanleitung
Instrucciones para el montaje
Istruzioni di installazione

Leeftijd
Age group
Age / Alter
Edad / Età
4 - 10

EUROPLAY nv
Eegene 9
B-9200 DENDERMONDE
tel. 32.52.22 66 22
fax.32.52.22 67 22
www.euoplay.eu

Dat.: 4/09/2020
Rev.: -
Page: 1/5

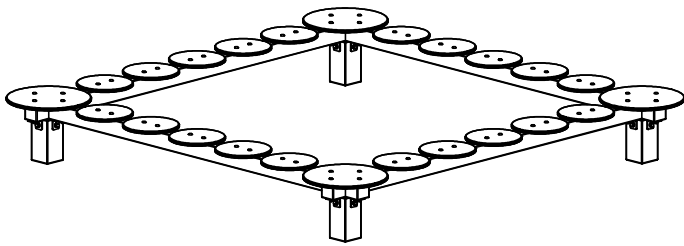

85kg

VALHOOGTE / HAUTEUR DE CHUTE /
FALL HEIGHT / FALLHÖHE/
ALTURA DE CAÍDA / ALTEZZA DI CADUTA

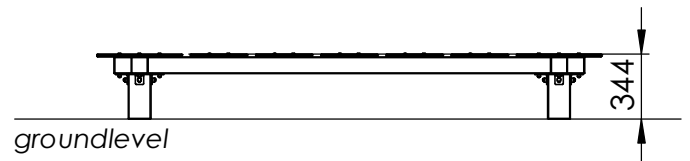



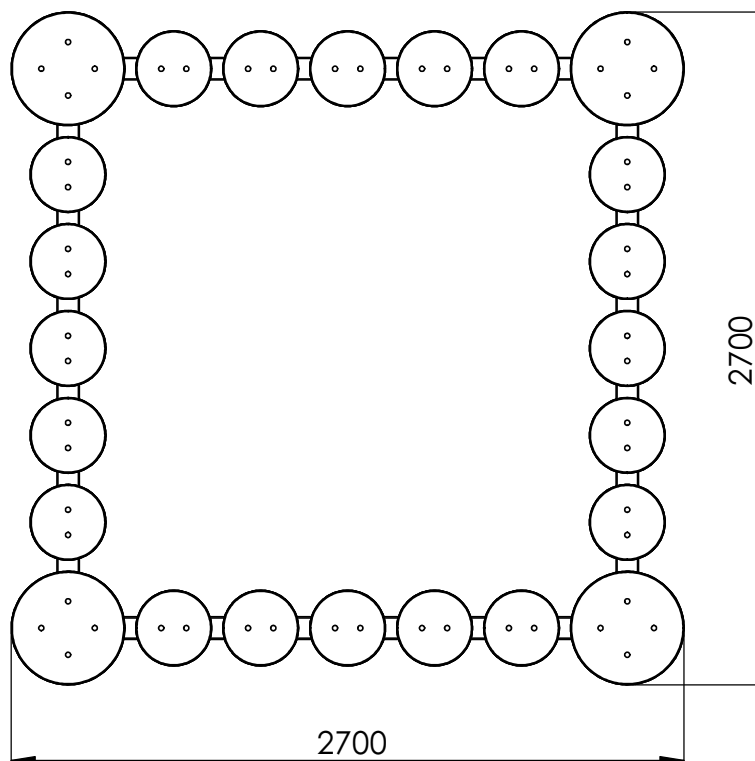



VEILIGHEIDSAFSTAND / ESPACE DE CHUTE / SAFETY AREA /
SICHERHEITSAFSTAND / ZONA DE SEGURIDAD / DISTANZA DI SICUREZZA

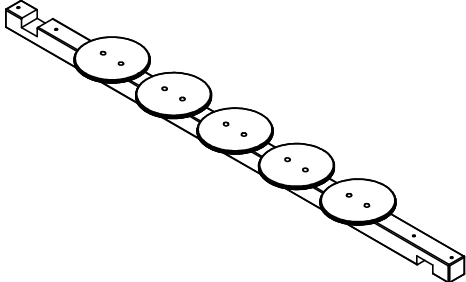
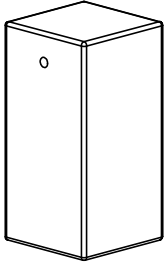
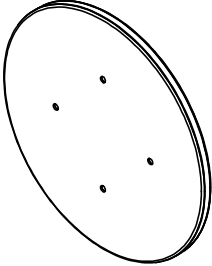
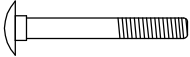
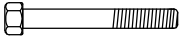
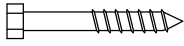

AFMETINGEN
DIMENSIONS
MASSE
DIMENSIONES
DIMENSIONI
L: 2,7m
Br: 2,7m
H: 0,4m

7,5m²

Benodigdheden - Liste des pièces - Materials - Benötigtes - Accesorios - Requisiti

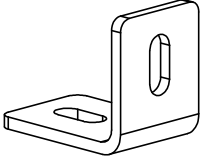
<p>4x P580-As-Balk-01</p>  <p>2490x89x89 14,40kg</p>	<p>4x P580-H-Voet-01</p>  <p>240x120x120 2,53kg</p>	
<p>4x Lb-K-WielD450x19</p>  <p>Ø450x19 2,86kg</p>		
<p>16x M8x120</p> 	<p>4x M10x145</p> 	<p>8x M10x50</p> 
<p>16x M8</p>  <p>16x M10</p> 	<p>16x M8</p>  <p>16x M10</p> 	<p>16x M8</p>  <p>4x M10</p> 
<p>16x Lb-M-BIHoek-01</p> 		

①

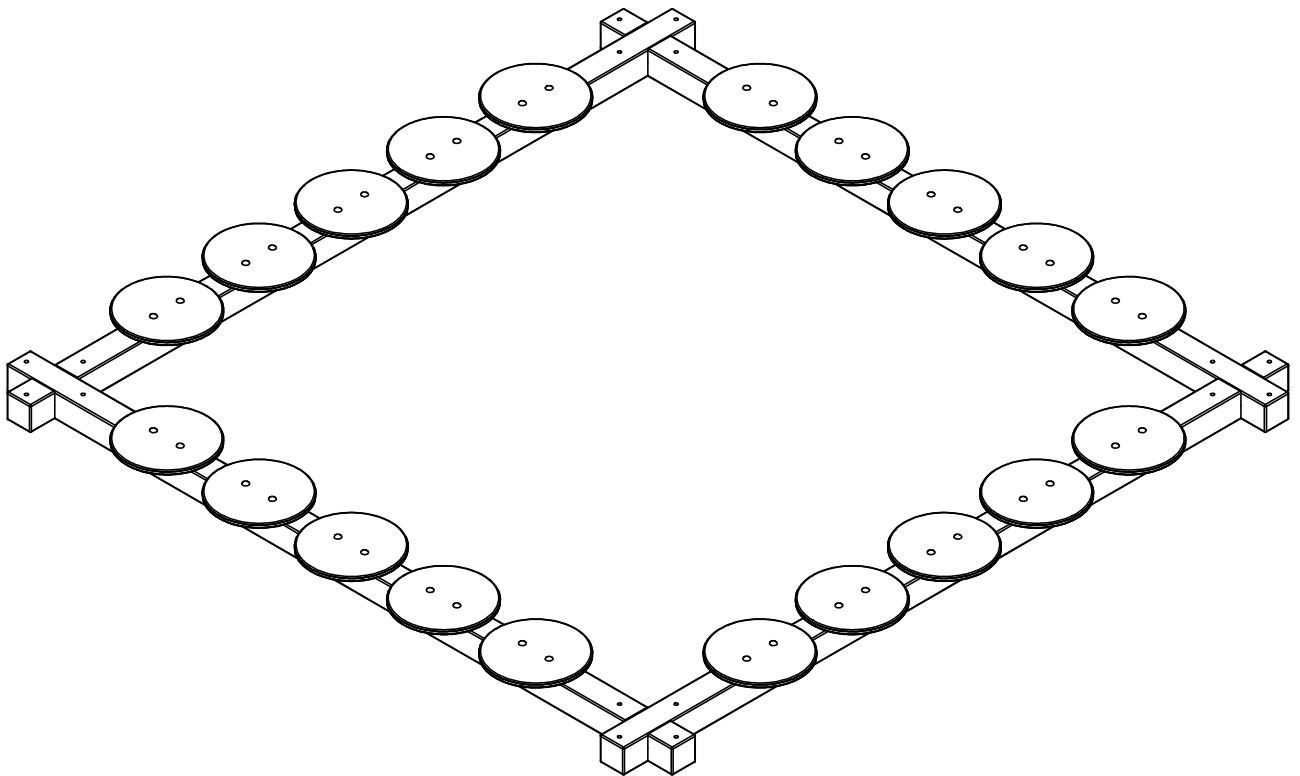
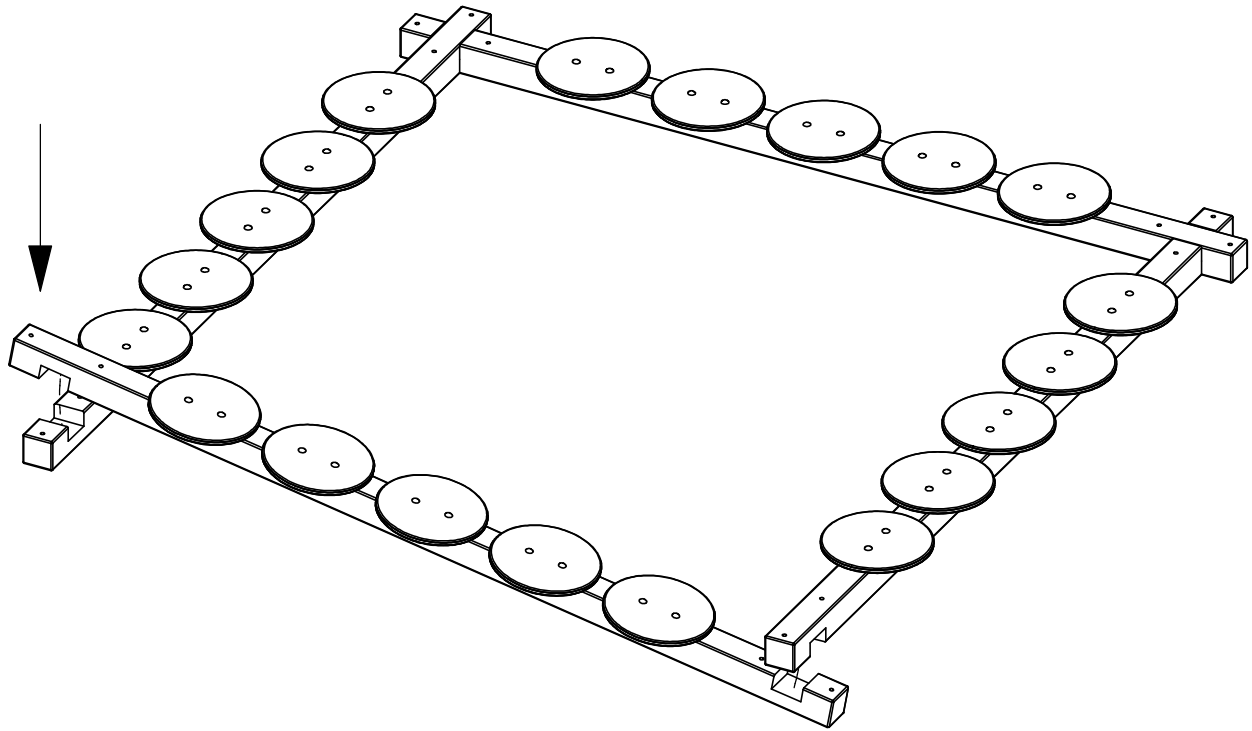

②

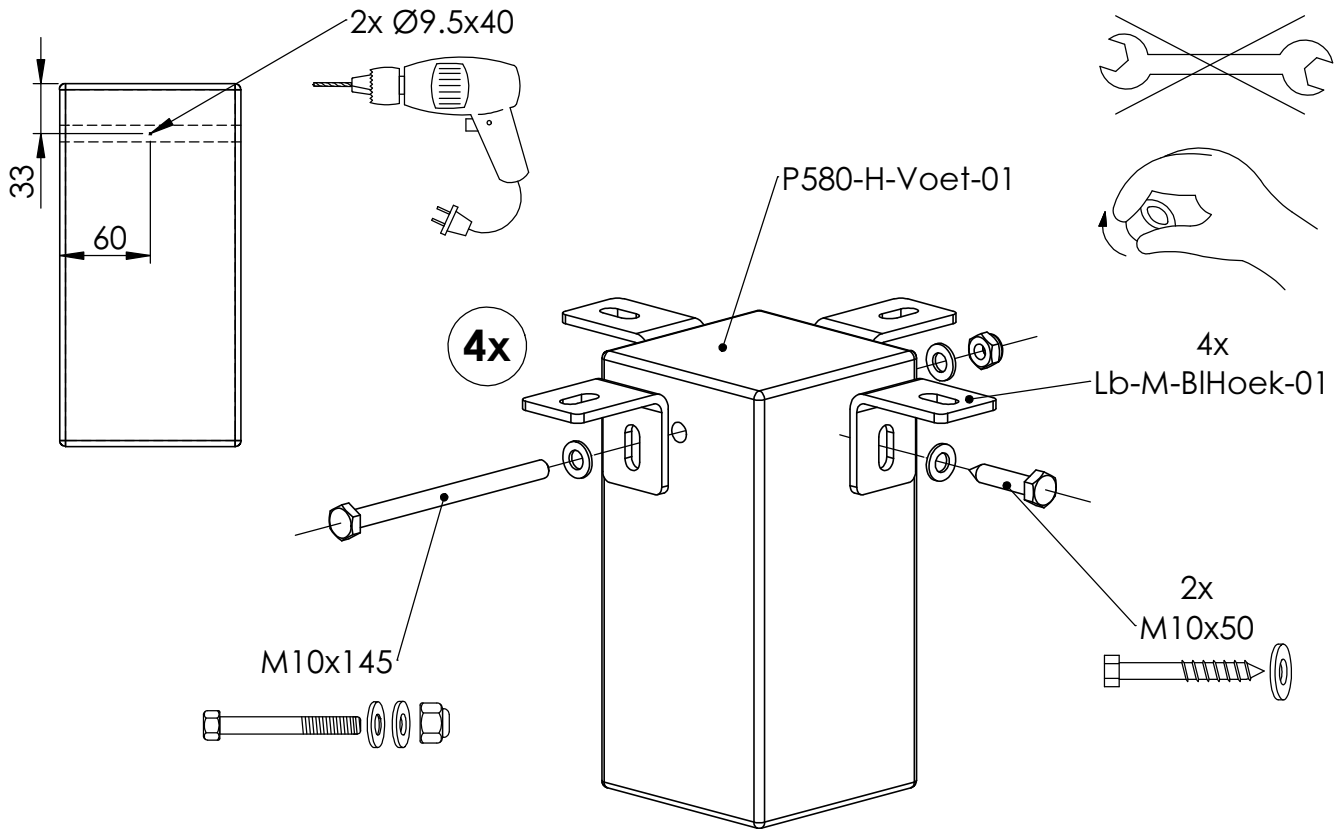

③

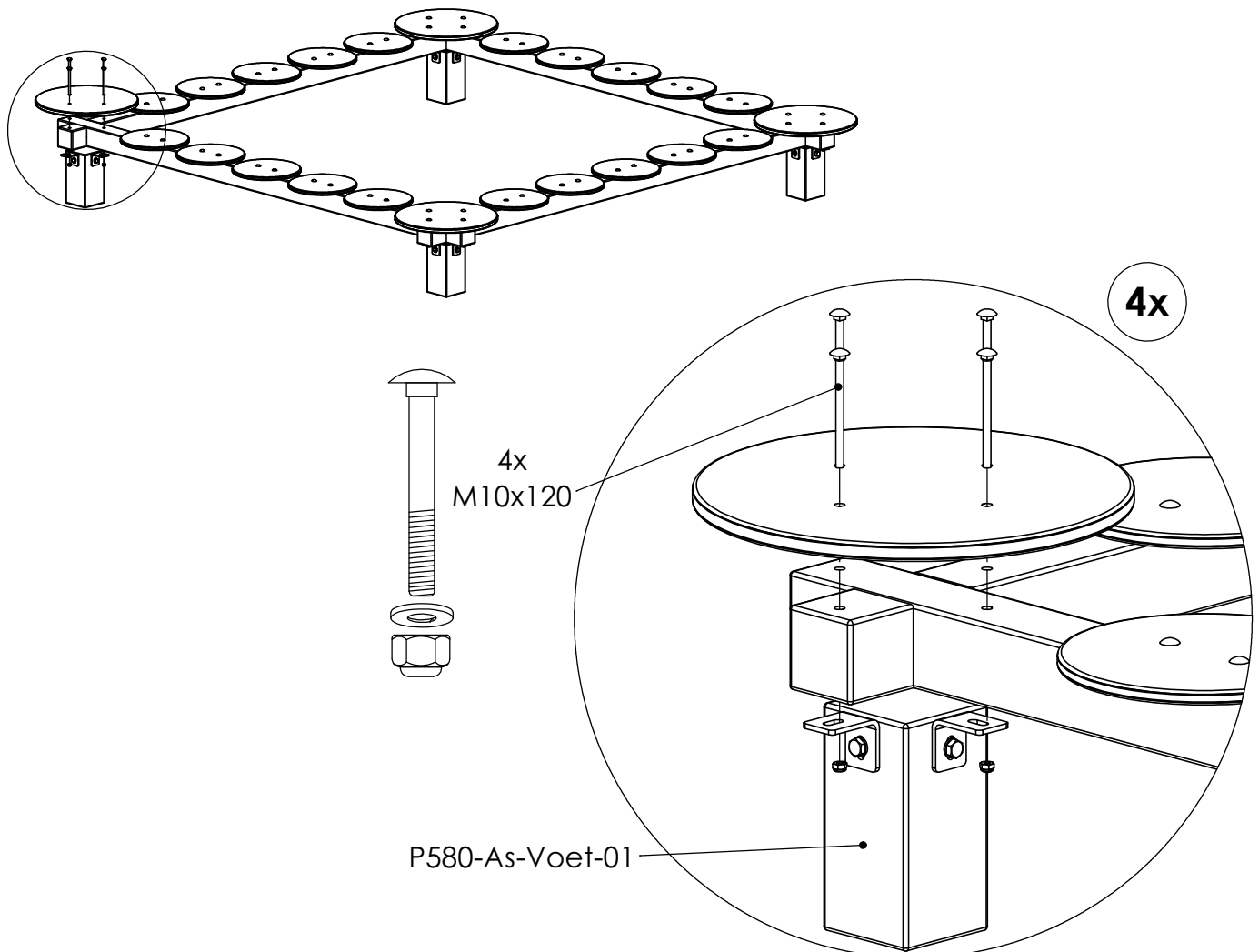

④

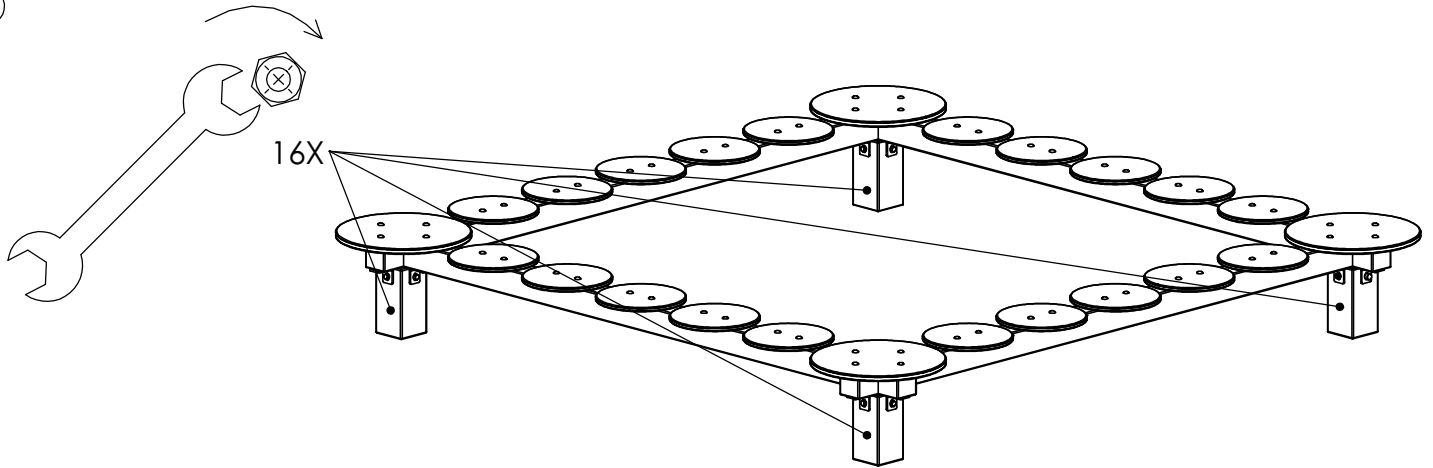

⑤

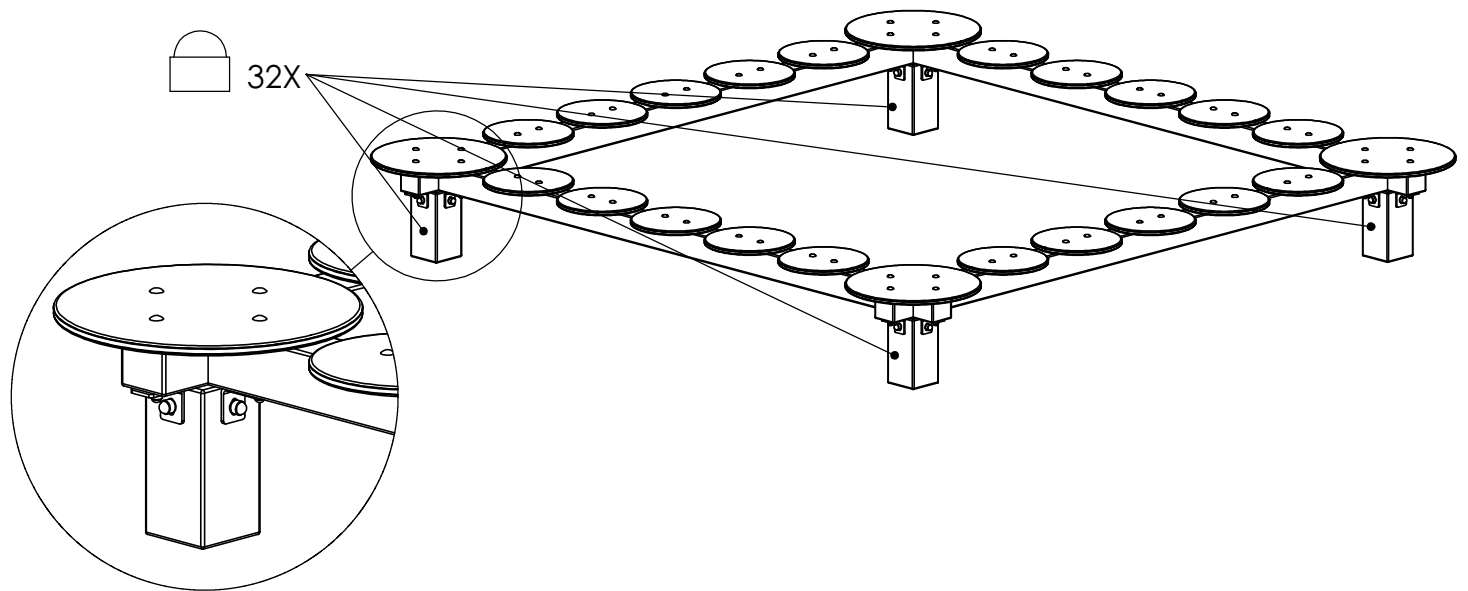

⑥

Bij droog weer moeten alle bouten en schroeven opnieuw aangespannen worden.
Par temps sec il faut resserrer régulièrement toute la visserie.
By dry and warm weather check the tightness of all bolts and screws.
Bei trockenem Wetter müssen alle Schrauben und Bolzen aufs neue angespannt werden.
Para el tiempo seco, se necesita cerrar o ajustar los tornillos y tuercas.
Con tempo asciutto, tutti i bulloni e le viti devono essere avvitati nuovamente.

