

# S302

WIP NEWTON (twee personen)  
POUTRE À BASCULE NEWTON  
(deux places)  
WIPPE NEWTON (Zweisitzer)  
SEESAW NEWTON (two-seater)  
BALANCÍN NEWTON (doble)  
BASCULA NEWTON (biposto)

## Montagehandleiding Notice de montage Assembling manual Montageanleitung Instrucciones para el montaje Istruzioni di installazione

Leeftijd  
Age group  
Age / Alter  
Edad / Età  
4 - 12

EUROPLAY nv  
Eegene 9  
B-9200 DENDERMONDE  
tel. 32.52.22 66 22  
fax.32.52.22 67 22  
www.europlay.eu

Dat.: 4/03/2021  
Rev.: -  
Page: 1/4

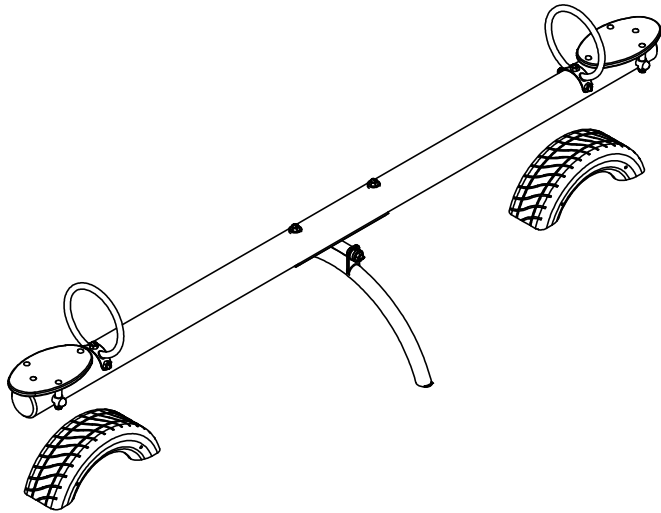

70 kg

VALHOOGTE / HAUTEUR DE CHUTE /  
FALL HEIGHT / FALLHÖHE/  
ALTURA DE CAÍDA / ALTEZZA DI CADUTA

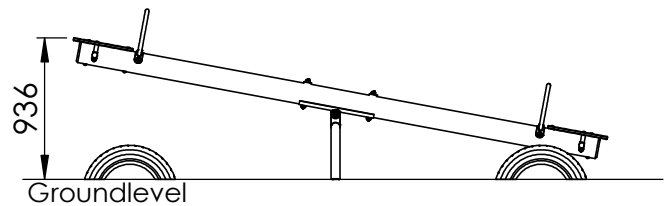

VEILIGHEIDSAFSTAND / ESPACE DE CHUTE / SAFETY AREA /  
SICHERHEITSAFSTAND / ZONA DE SEGURIDAD / DISTANZA DI SICUREZZA

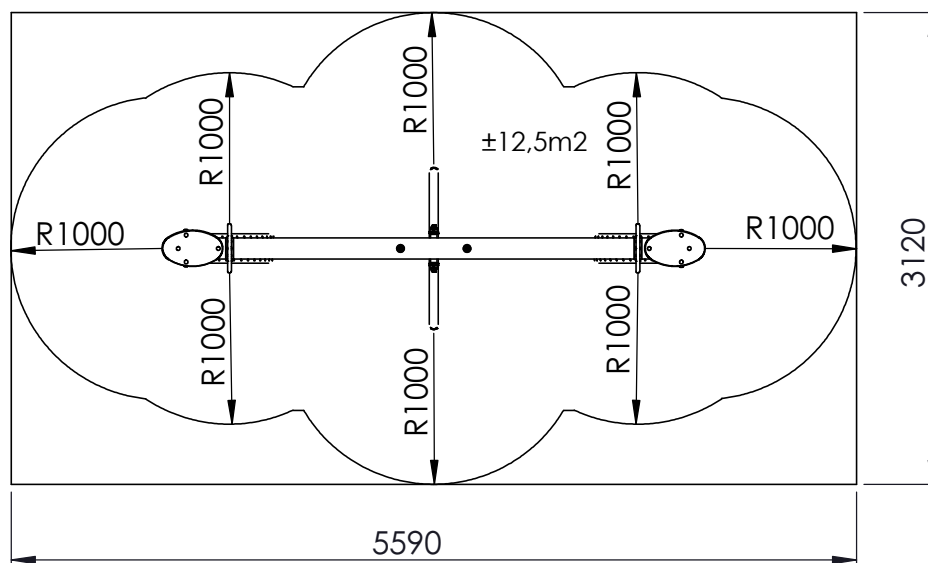

AFMETINGEN  
DIMENSIONS  
MASSE  
DIMENSIONES  
DIMENSIONI  
L: 3,6m  
Br: 1m  
H: 0,9m

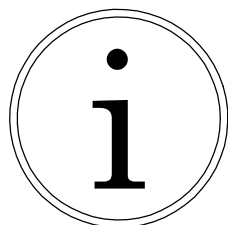



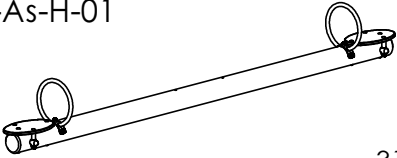
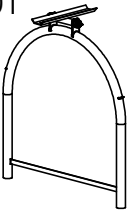
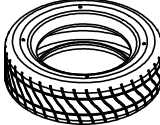

Zone niet overlappen.  
Ne pas chevaucher la zone.  
Do not overlap zone.  
Zone nicht überlappen  
No superponer la zona  
Non sovrapporre la zona

±17,5m2

## Benodigdheden - Liste des pièces - Materials - Benötigtes - Accesorios - Requisiti

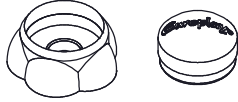
1x S302-As-H-01	
3600x325x442	31.87kg
1x S302-As-Beugel-01	
1230x1120x500	17.05kg
2x L100-A-AutoBand-01	
195xØ625	9.28kg

2x M10x170	
2x M10	
4x White	
2x Blue	

①

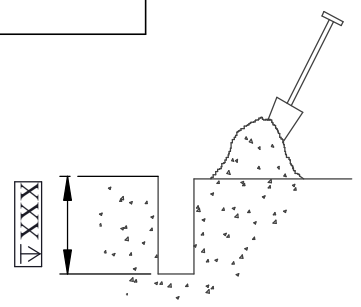
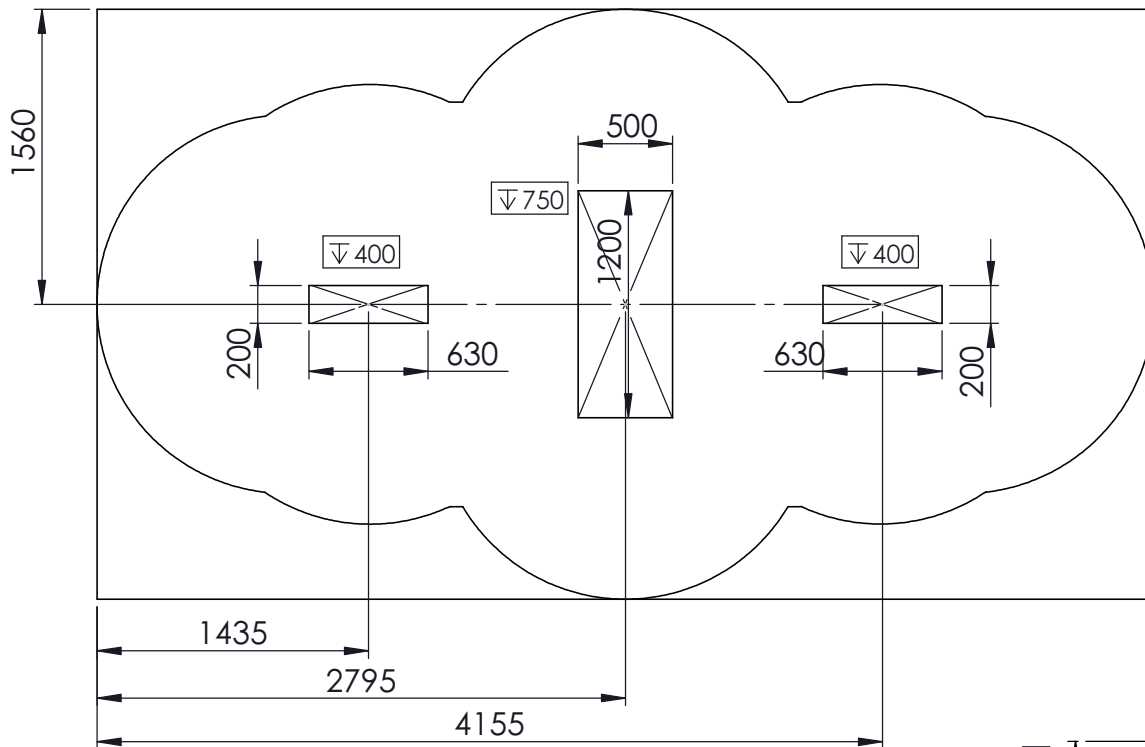

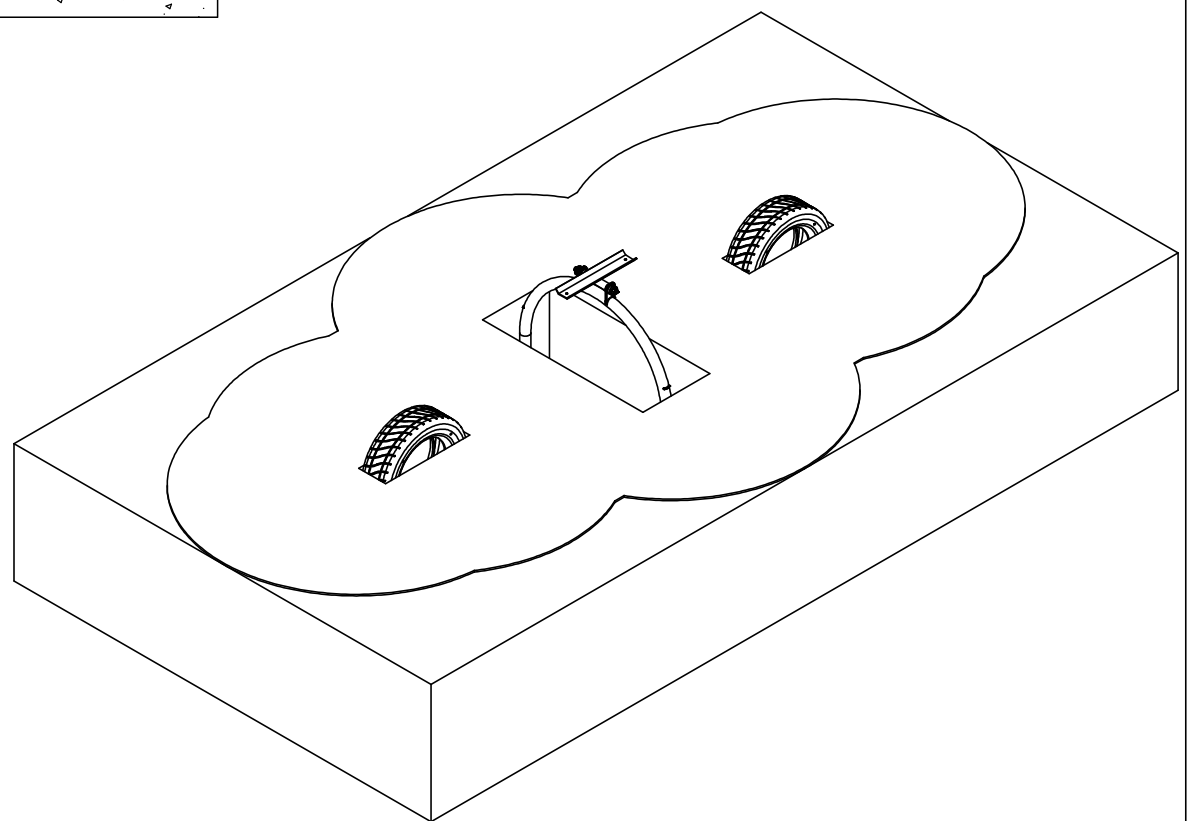
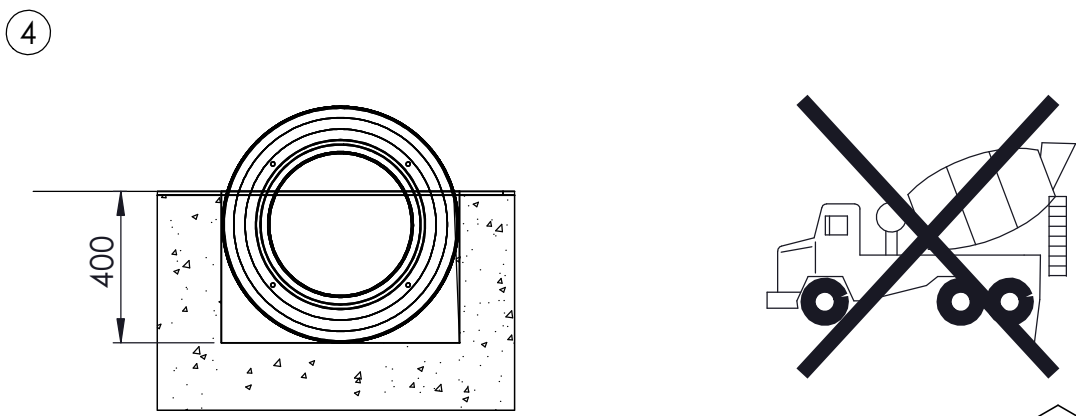
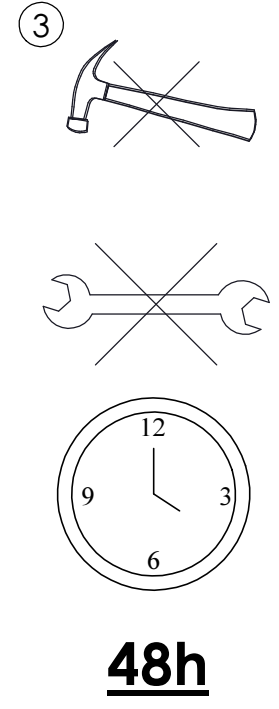
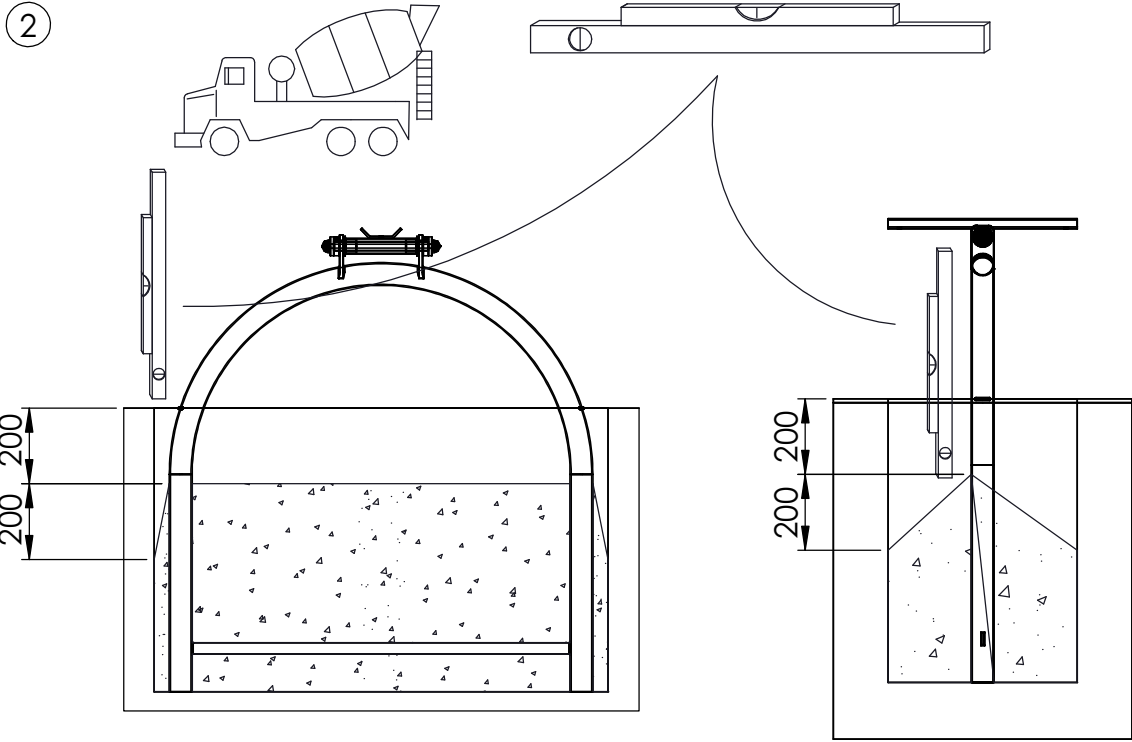

5

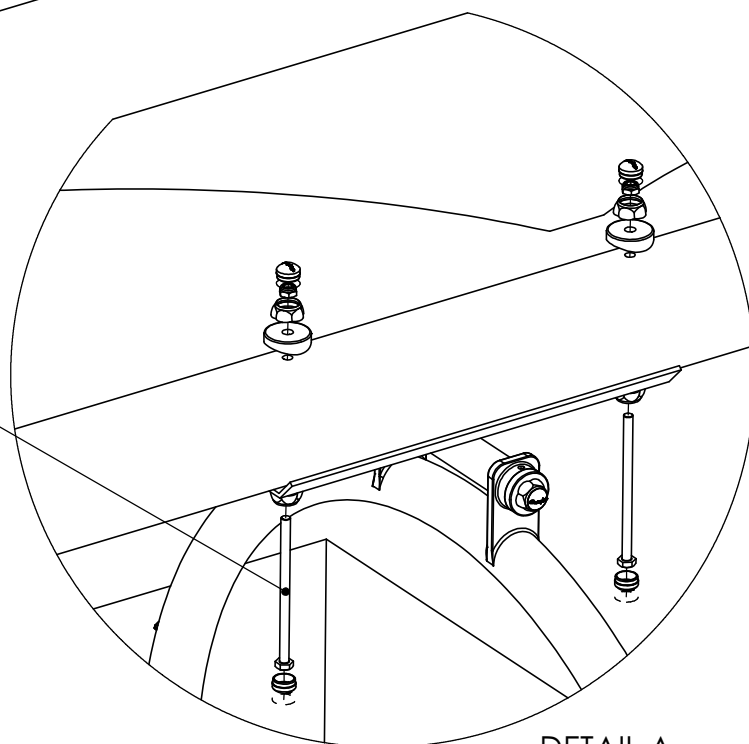
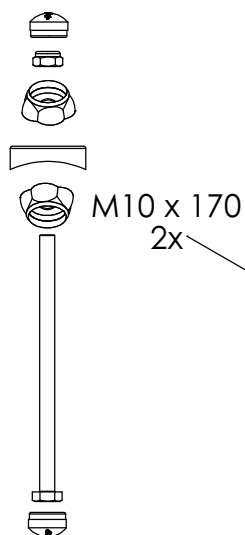
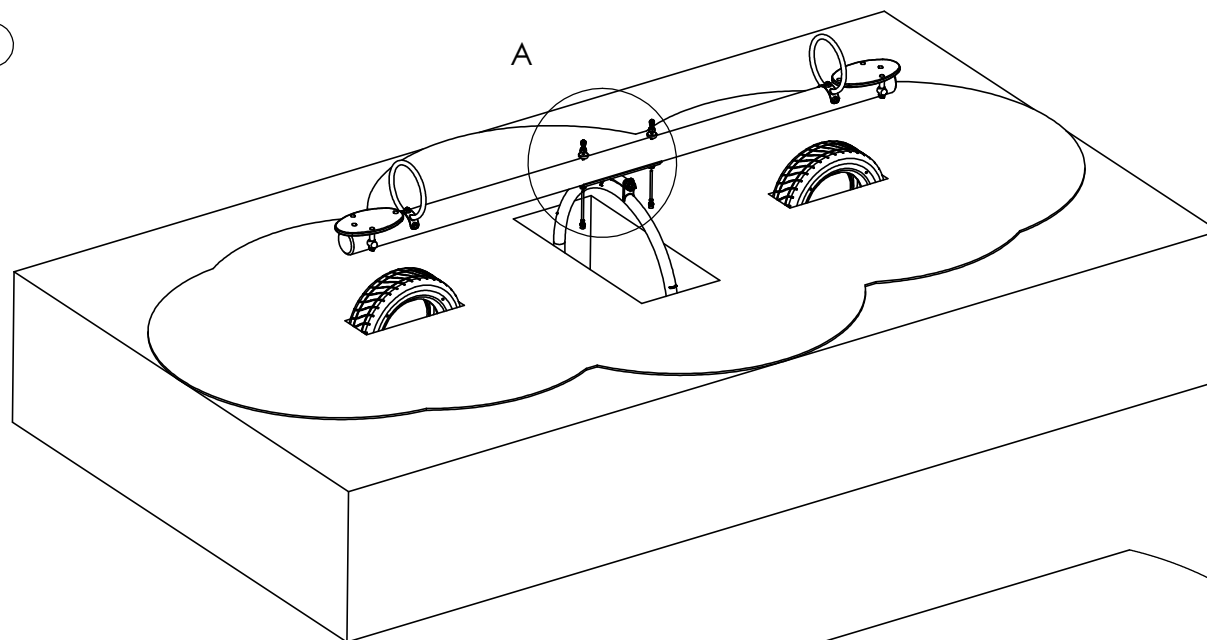
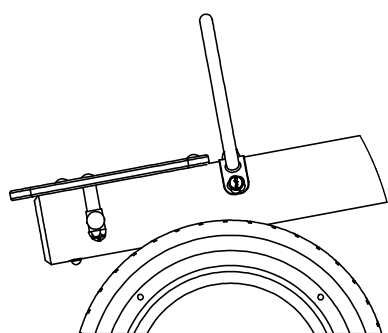
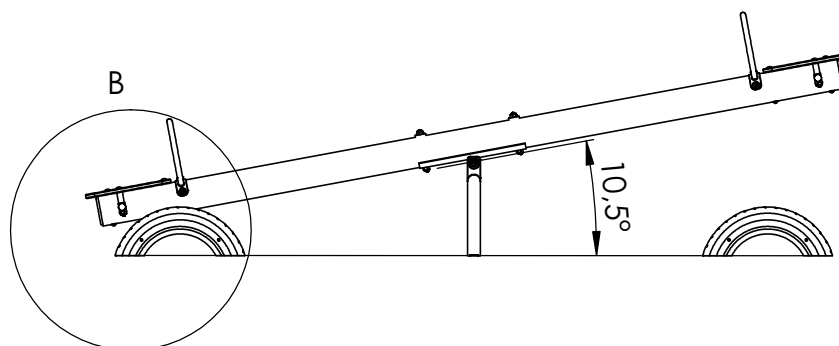
DETAIL A  
SCALE 1 : 8DETAIL B  
SCALE 1 : 15

- 6 Bij droog weer moeten alle bouten en schroeven opnieuw aangespannen worden.  
Par temps sec il faut resserrer régulièrement toute la visserie.  
By dry and warm weather check the tightness of all bolts and screws.  
Bei trockenem Wetter müssen alle Schrauben und Bolzen aufs neue angespannt werden.  
Para el tiempo seco, se necesita cerrar o ajustar los tornillos y tuercas.  
Con tempo asciutto, tutti i bulloni e le viti devono essere avvitate nuovamente.