

E400

Navigator

Montagehandleiding
Notice de montage
Assembling manual
Montageanleitung
Instrucciones para el montaje
Istruzioni di installazione

Leeftijd
Age group
Age / Alter
Edad / Età
6 - 15

EUROPLAY nv
Eegene 9
B-9200 DENDERMONDE
tel. 32.52.22 66 22
fax.32.52.22 67 22
www.euoplay.eu

Dat.: 29/01/2019
Rev.: -
Page: 1/4

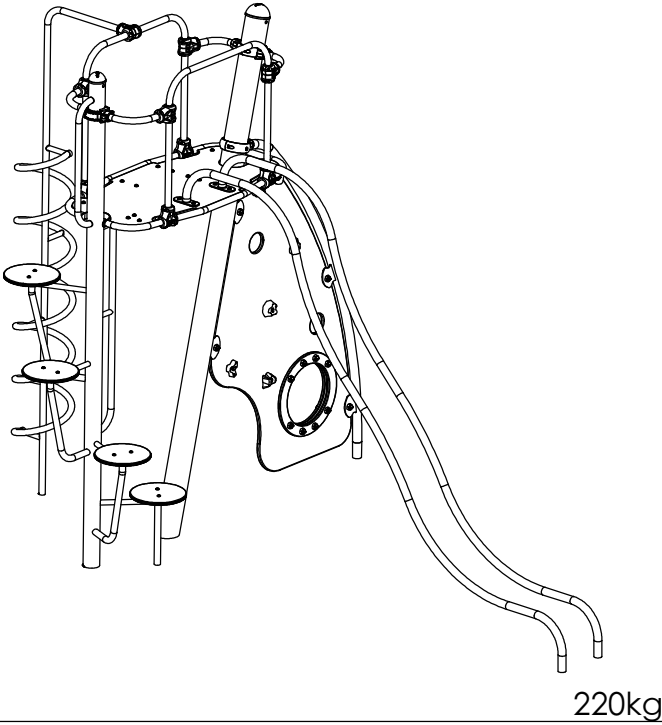

VALHOOGTE / HAUTEUR DE CHUTE /
FALL HEIGHT / FALLHÖHE/
ALTURA DE CAÍDA / ALTEZZA DI CADUTA

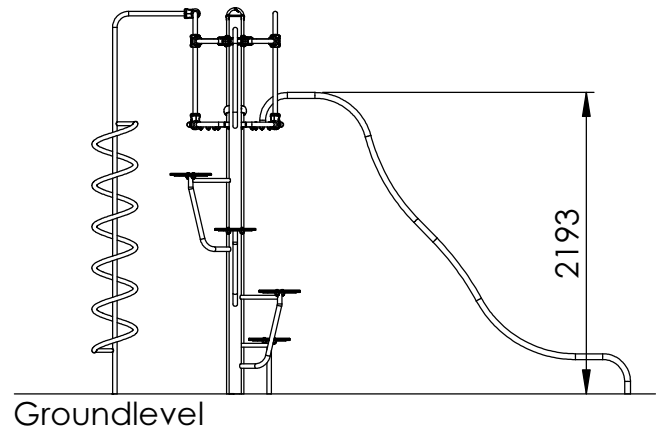

VEILIGHEIDSAFSTAND / ESPACE DE CHUTE / SAFETY AREA /
SICHERHEITSAFSTAND / ZONA DE SEGURIDAD / DISTANZA DI SICUREZZA

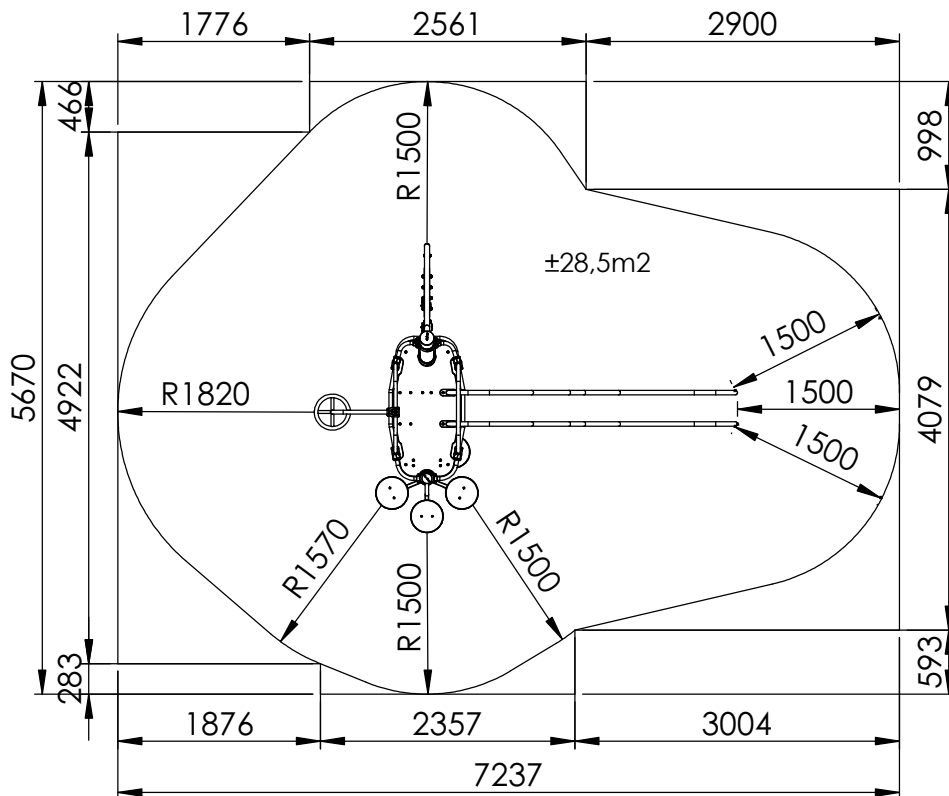

AFMETINGEN
DIMENSIONS
MASSE
DIMENSIONES
DIMENSIONI
L: 4m
Br: 2,7m
H: 2,8m

±35,5m²

Benodigdheden - Liste des pièces - Materials - Benötigtes - Accesorios - Requisiti

1x E061

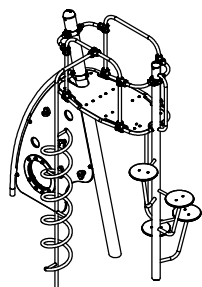
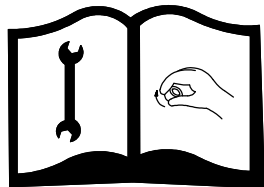

2x E060-M-Glijbuis-01

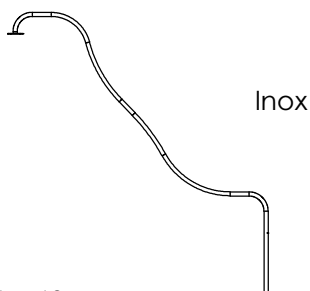

2973,1 x 2758,1 x 60

12.87kg

2x E000-M-Grondanker-01

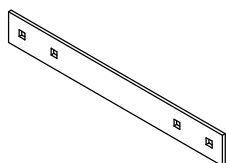

400 x 50 x 5

0.76kg

2x Lb-H-Steunblok-01

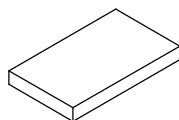

4x M10x70

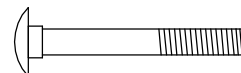

4x M10x45

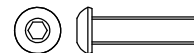

8x M10



8x M10



4x White



①

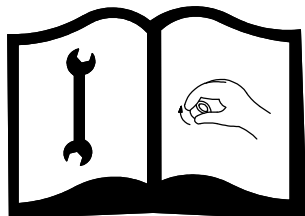
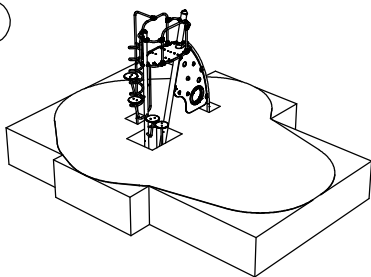

E061

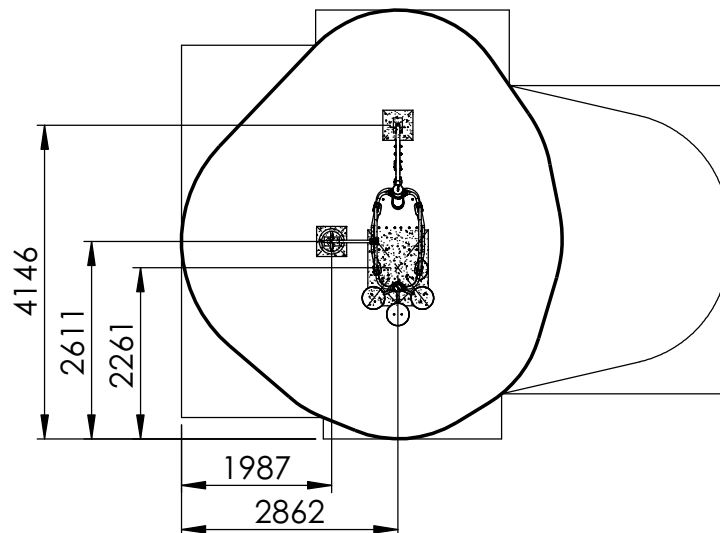
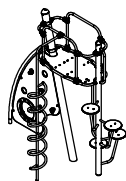

① → ⑧ ⑨ → ⑩

②

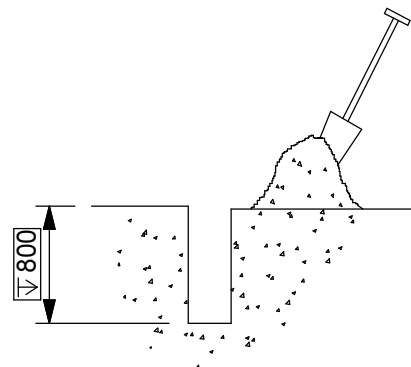
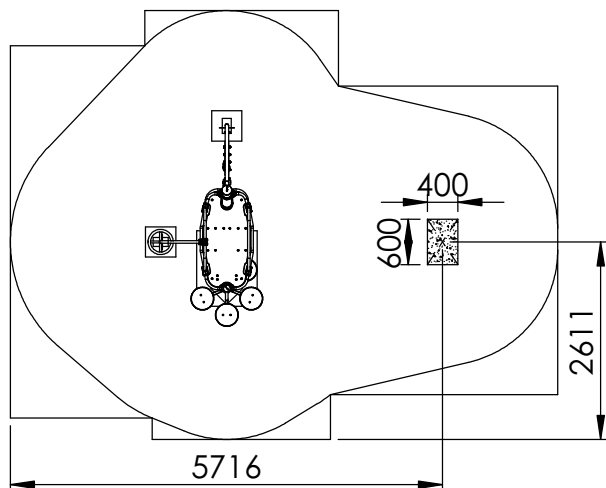

③

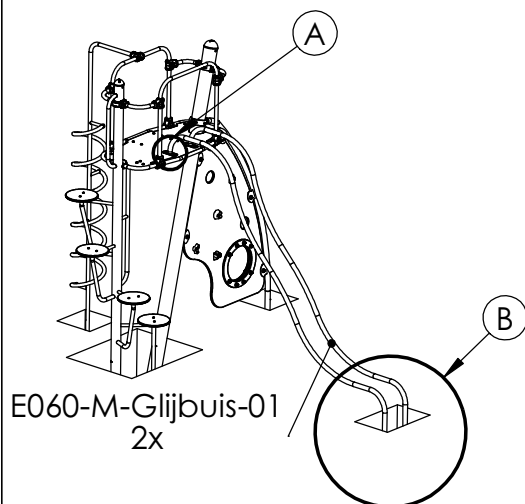

③A 2x

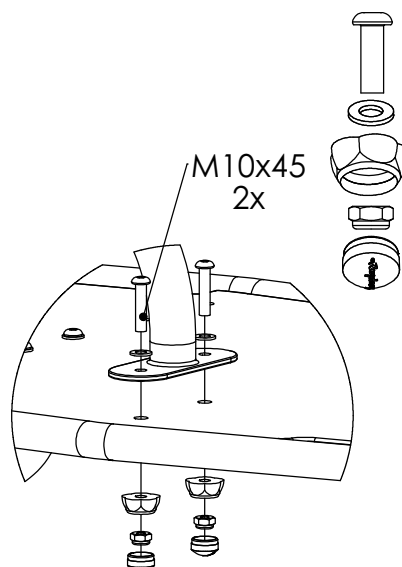

③B

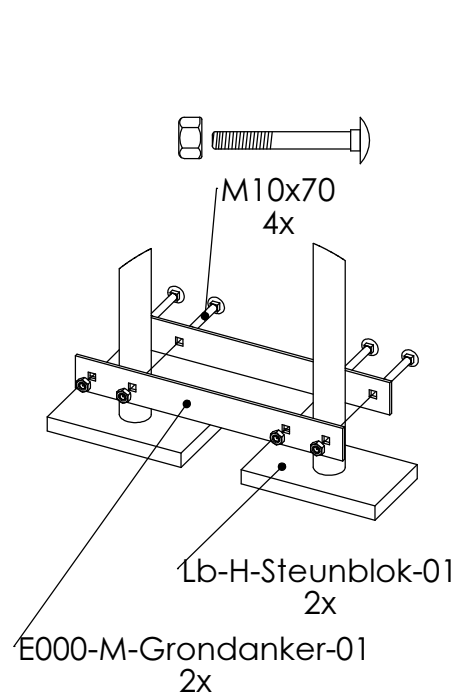

4

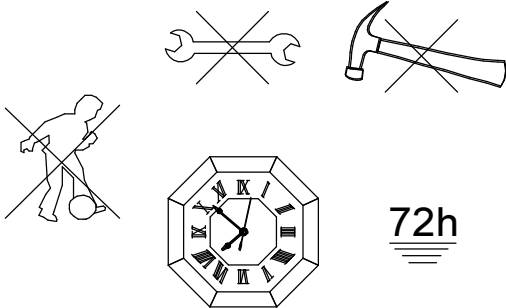
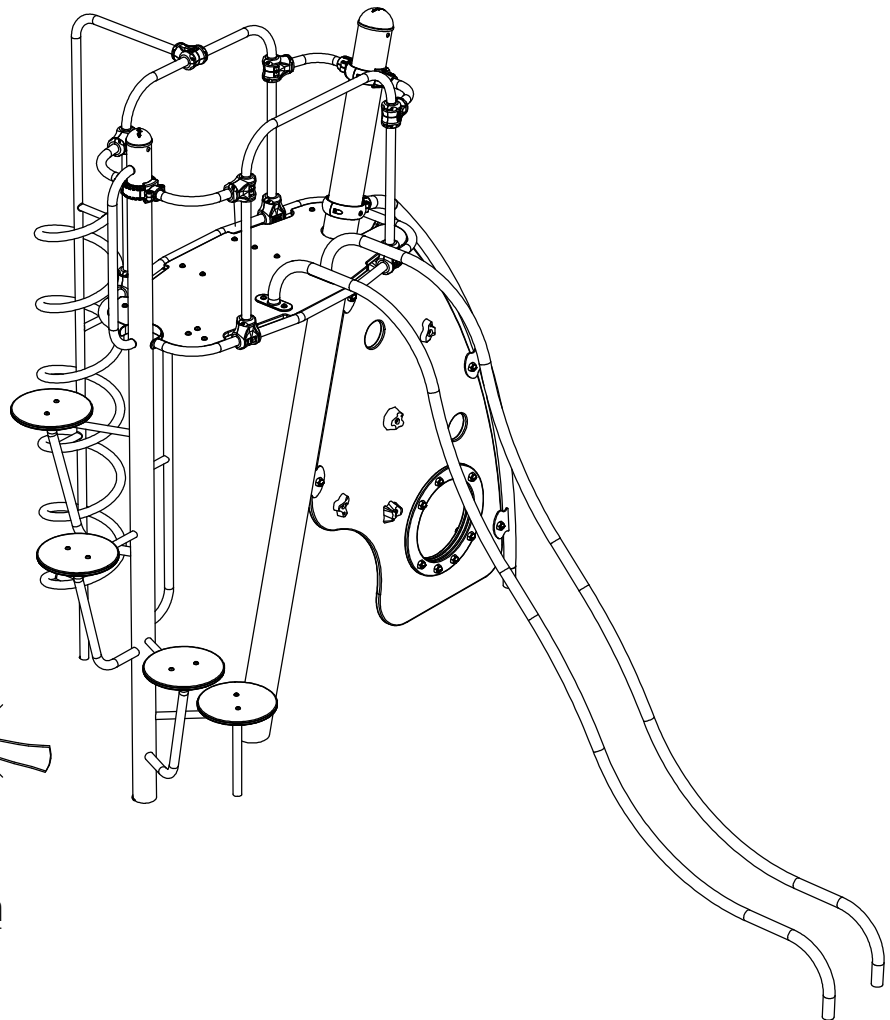
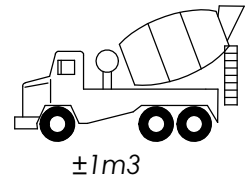
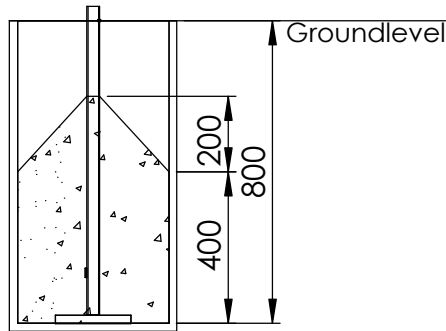
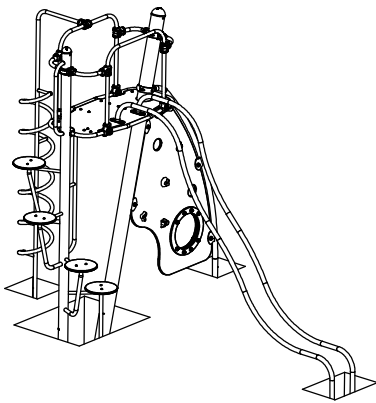

72h

5

Bij droog weer moeten alle bouten en schroeven opnieuw aangespannen worden.
 Par temps sec il faut resserrer régulièrement toute la visserie.
 By dry and warm weather check the tightness of all bolts and screws.
 Bei trockenem Wetter müssen alle Schrauben und Bolzen aufs neue angespannt werden.
 Para el tiempo seco, se necesita cerrar o ajustar los tornillos y tuercas.
 Con tempo asciutto, tutti i bulloni e le viti devono essere avvitati nuovamente.