

A410A/B

WANDELENDE TAK
BÂTON DE BOIS
LOG WALK
BALANCEBALKEN
LOMBRIZ
PERCORSO SU TRAVE

Montagehandleiding Notice de montage Assembling manual Montageanleitung Instrucciones para el montaje Istruzioni di installazione

Leeftijd
Age group
Age / Alter
Edad / Età
2 - 6

EUROPLAY nv
Eegene 9
B-9200 DENDERMONDE
tel. 32.52.22 66 22
fax.32.52.22 67 22
www.europlay.eu

Dat.: 13/07/2021
Rev.: -
Page: 1/3

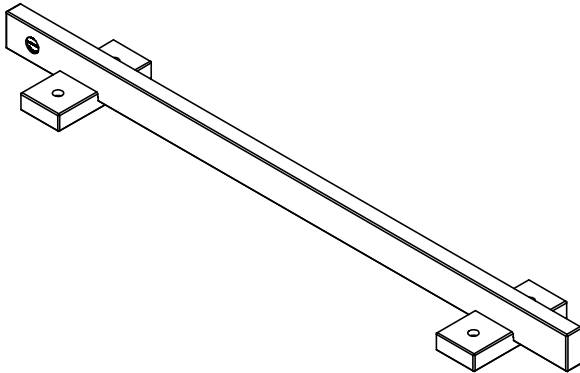

±20kg

VALHOOGTE / HAUTEUR DE CHUTE /
FALL HEIGHT / FALLHÖHE/
ALTURA DE CAÍDA / ALTEZZA DI CADUTA

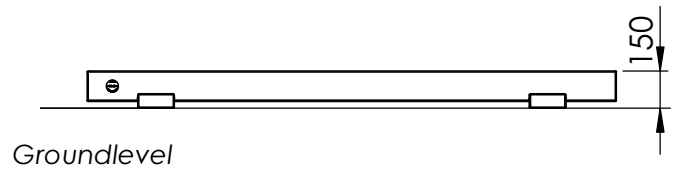
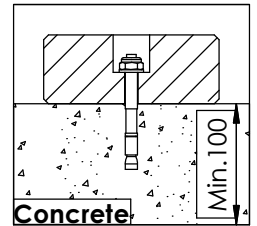

VEILIGHEIDSAFSTAND / ESPACE DE CHUTE / SAFETY AREA /
SICHERHEITSAFSTAND / ZONA DE SEGURIDAD / DISTANZA DI SICUREZZA

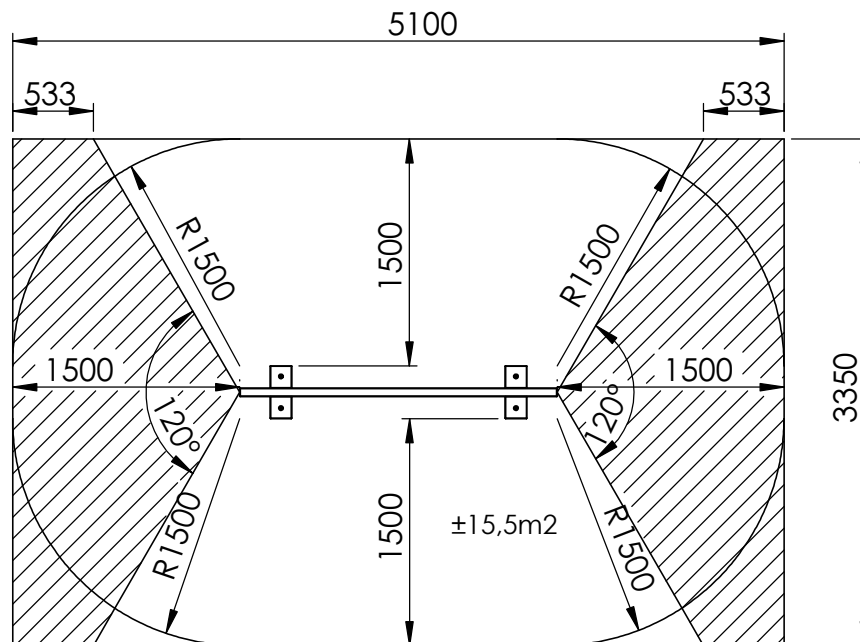

AFMETINGEN
DIMENSIONS
MASSE
DIMENSIONES
DIMENSIONI
L: 2,1m
Br: 0,35m
H: 0,15m

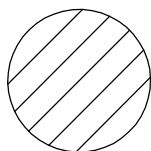



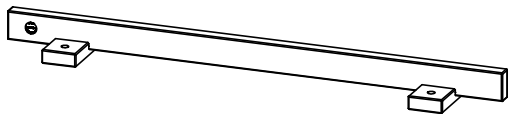

Samenvoegingszone avonturenpad
Zone de liaison parcours d'aventures
Verbindungsfeld survival parcours
Linking zone adventure path
Zona de conexión recorrido aventurero
Zona di allineamento percorso d'avventura

±17,5m²

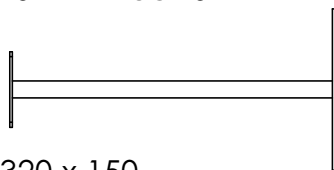
Benodigdheden - Liste des pièces - Materials - Benötigtes - Accesorios - Requisiti

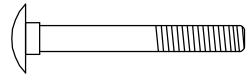
| |
|---|
| 410-As-Wandelendetak-01 |
|  |
| 2,1x0,35x0,15 |
| 15,88kg |

| A410A | | A410B | |
|--------------------|---|------------|---|
| 2x A410-M-AVoet-01 |  | 4x M10x115 |  |
| 645 x 320 x 150 | 2.72kg | | |
| 4x M10x55 |  | | |
| 4x M10 |  | | |
| 4x M10 |  | | |

①

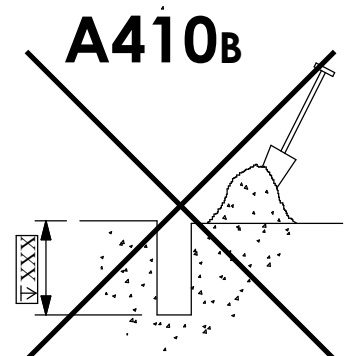
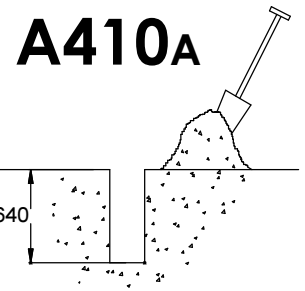
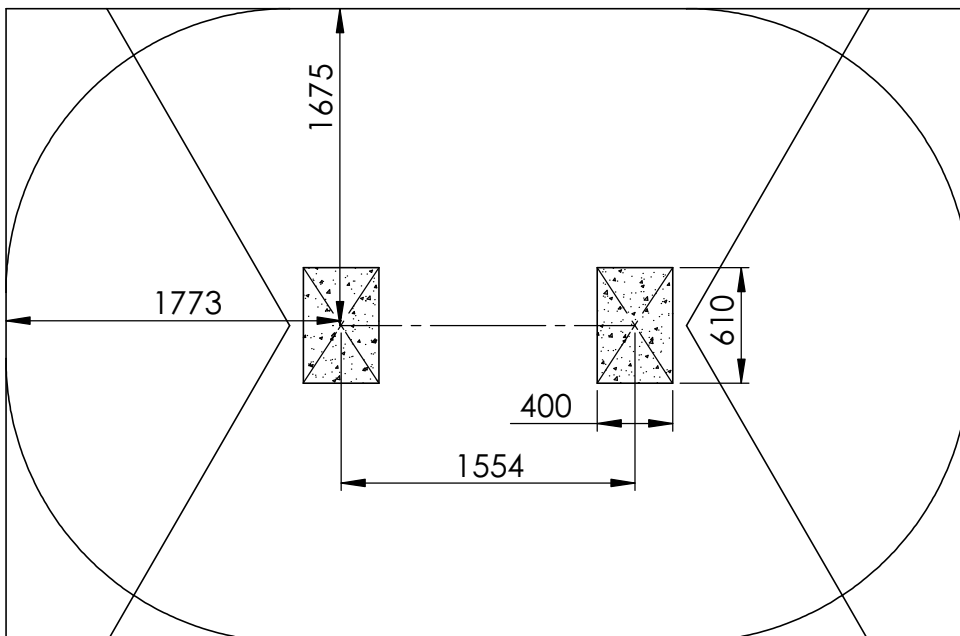

②

A410A

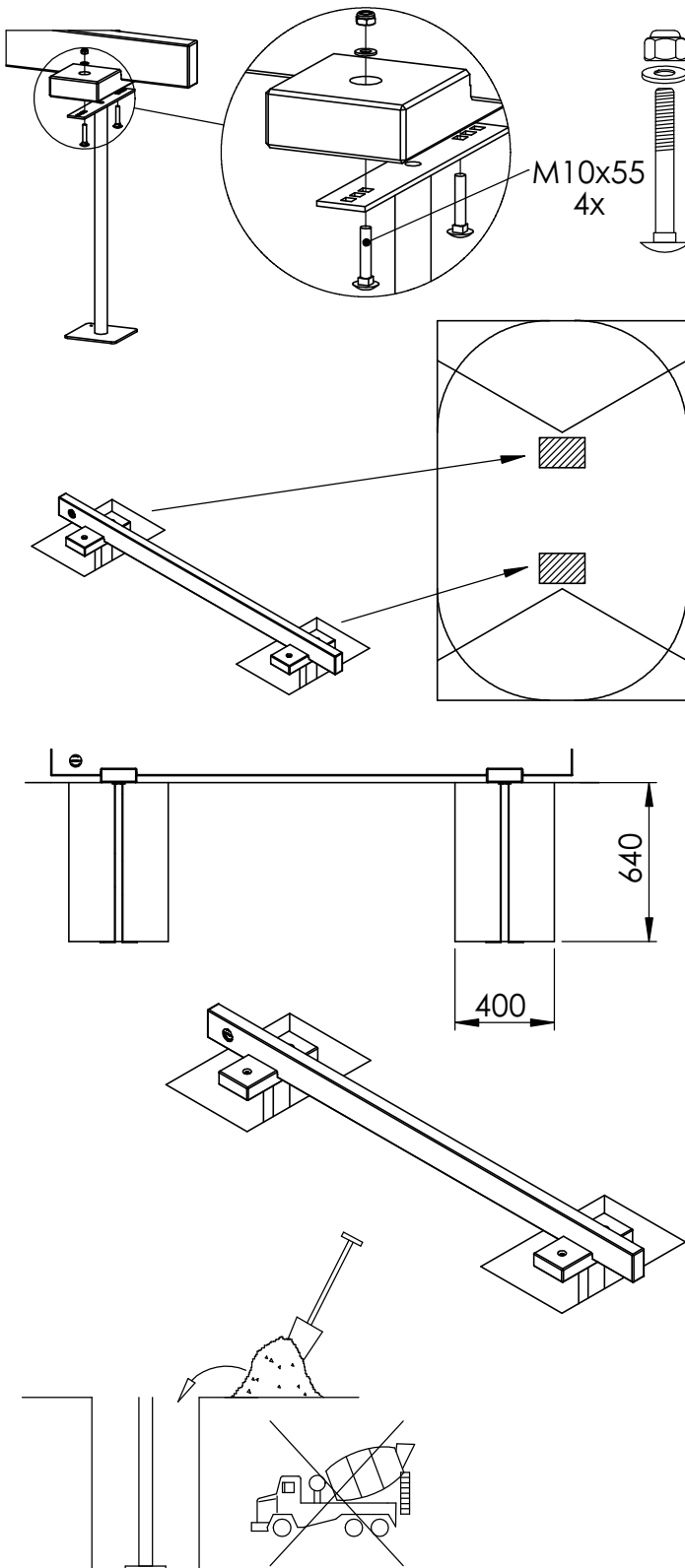

A410B

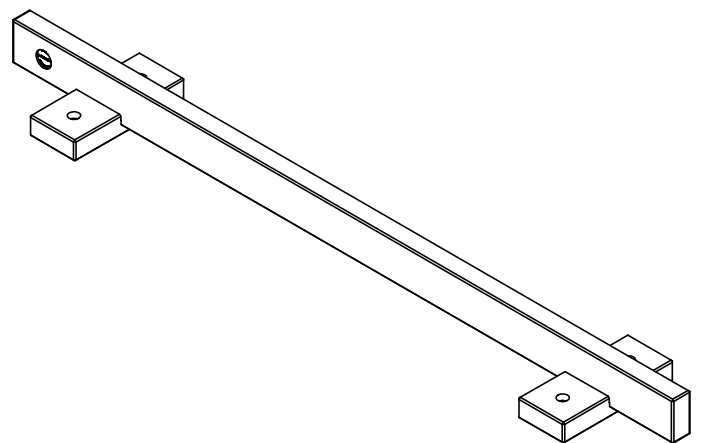
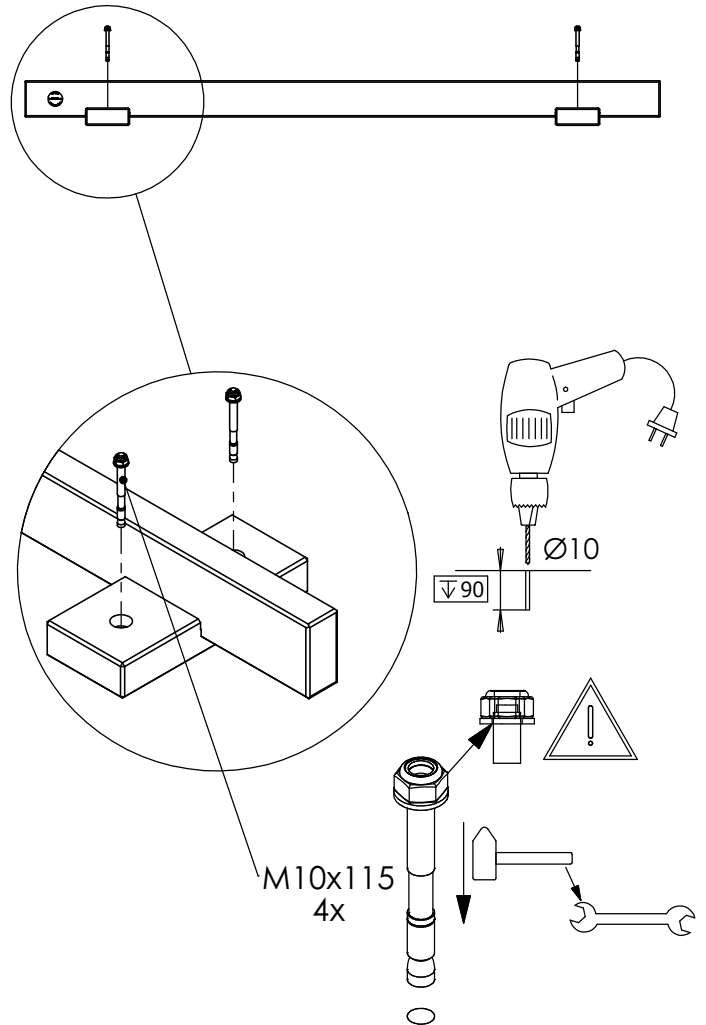

Bij droog weer moeten alle bouten en schroeven opnieuw aangespannen worden.
 Par temps sec il faut resserrer régulièrement toute la visserie.

By dry and warm weather check the tightness of all bolts and screws.

Bei trockenem Wetter müssen alle Schrauben und Bolzen aufs neue angespannt werden.

Para el tiempo seco, se necesita cerrar o ajustar los tornillos y tuercas.

Con tempo asciutto, tutti i bulloni e le viti devono essere avvitati nuovamente.

④