

RO540

COMBI-TOVERTOREN
COMBI-TOUR MAGIQUE
MAGIC TOWER COMBINATION
KOMBI ZAUBERTURM
LA TORRE DE MAGIA
COMBINACIÓN
COMBI-TORRE INCANTATA

Montagehandleiding Notice de montage Assembling manual Montageanleitung Instrucciones para el montaje Istruzioni di installazione

Leeftijd
Age group
Age / Alter
Edad / Età
4 - 12

EUROPLAY nv
Eegene 9
B-9200 DENDERMONDE
tel. 32.52.22 66 22
fax.32.52.22 67 22
www.europly.eu

Dat.: 7/09/2021
Rev.: -
Page: 1/8

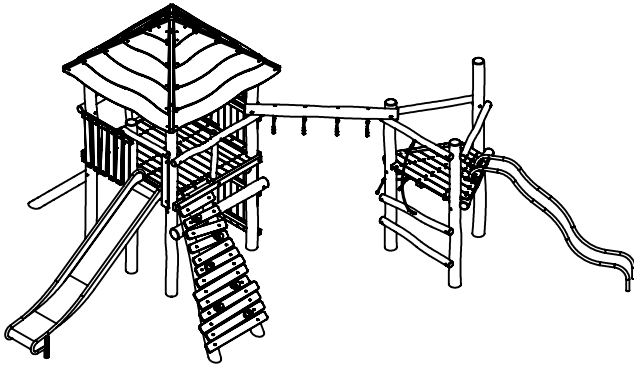

±1170kg

VALHOOGTE / HAUTEUR DE CHUTE /
FALL HEIGHT / FALLHÖHE/
ALTURA DE CAÍDA / ALTEZZA DI CADUTA

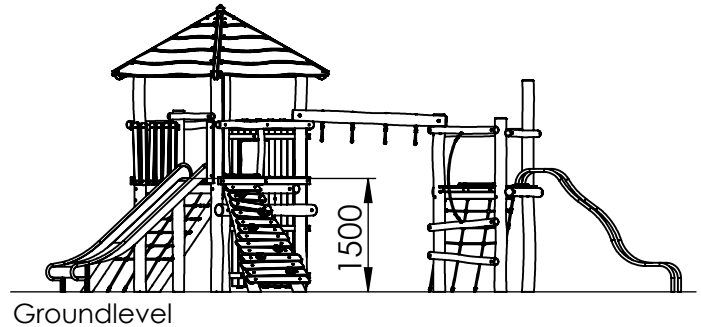

VEILIGHEIDSAFSTAND / ESPACE DE CHUTE / SAFETY AREA /
SICHERHEITSAFSTAND / ZONA DE SEGURIDAD / DISTANZA DI SICUREZZA

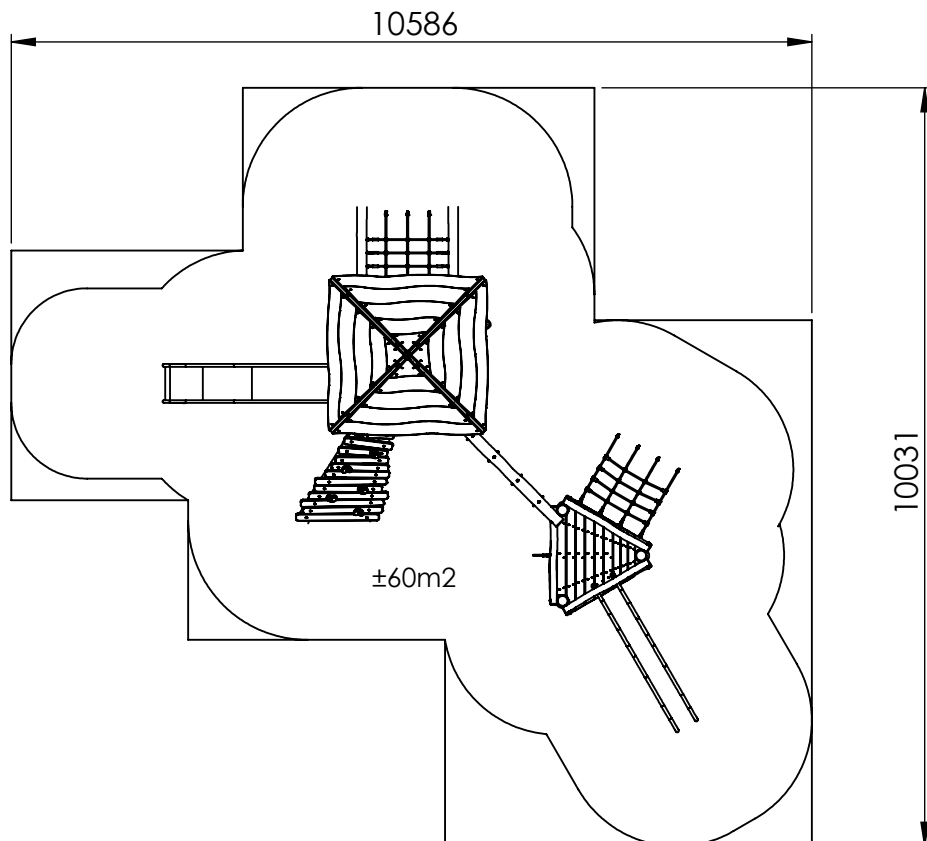

AFMETINGEN
DIMENSIONS
MASSE
DIMENSIONES
DIMENSIONI
L: 8,4m
Br: 4,6m
H: 3,8m

±71m²

Benodigdheden - Liste des pièces - Materials - Benötigtes - Accesorios - Requisiti

1x RO531

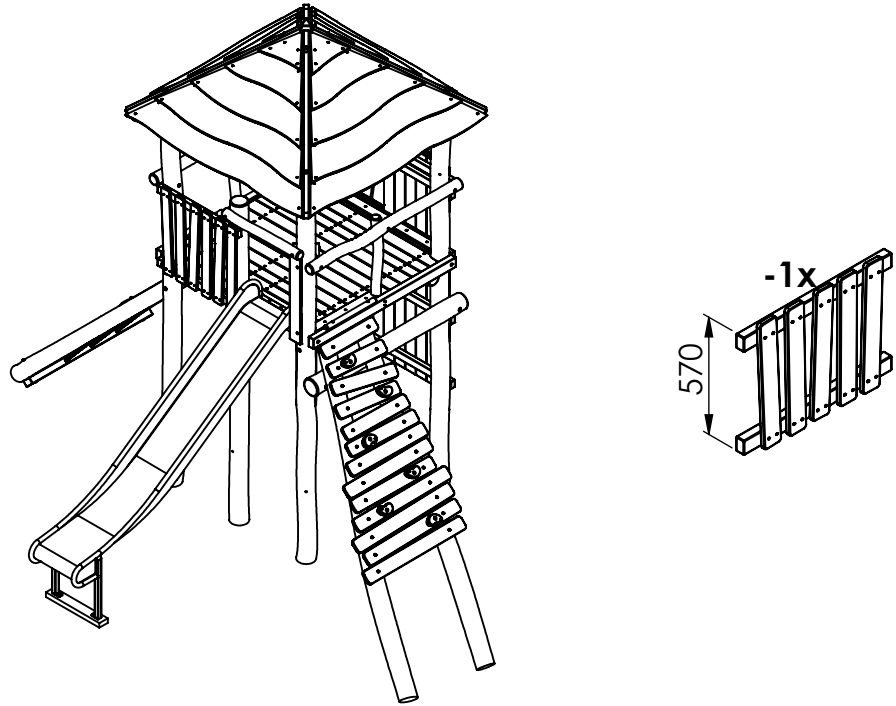

1x RO510

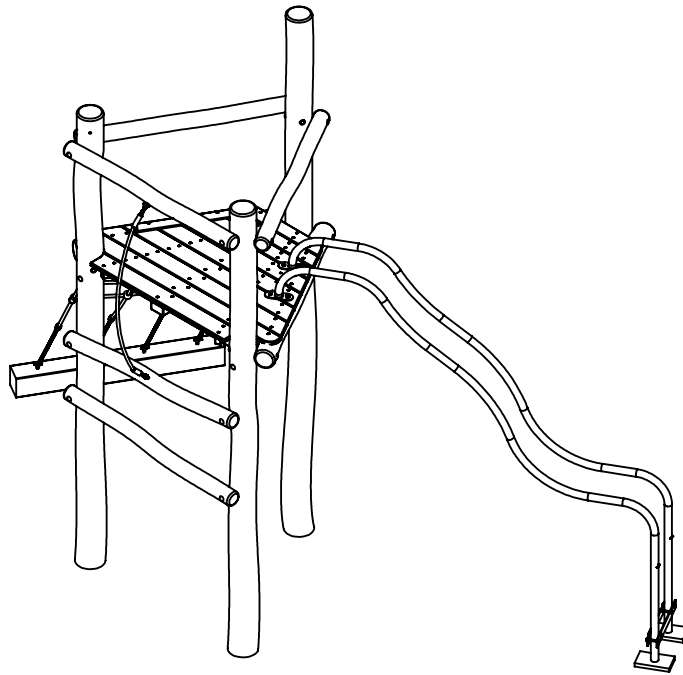

1x RO540-As-A-01

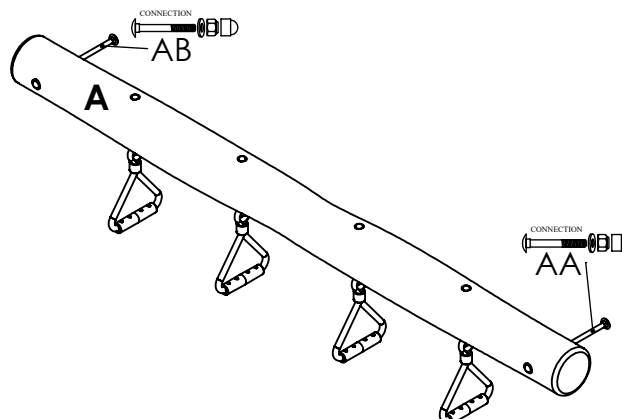

(2038xØ140-Ø160)

(±30kg)

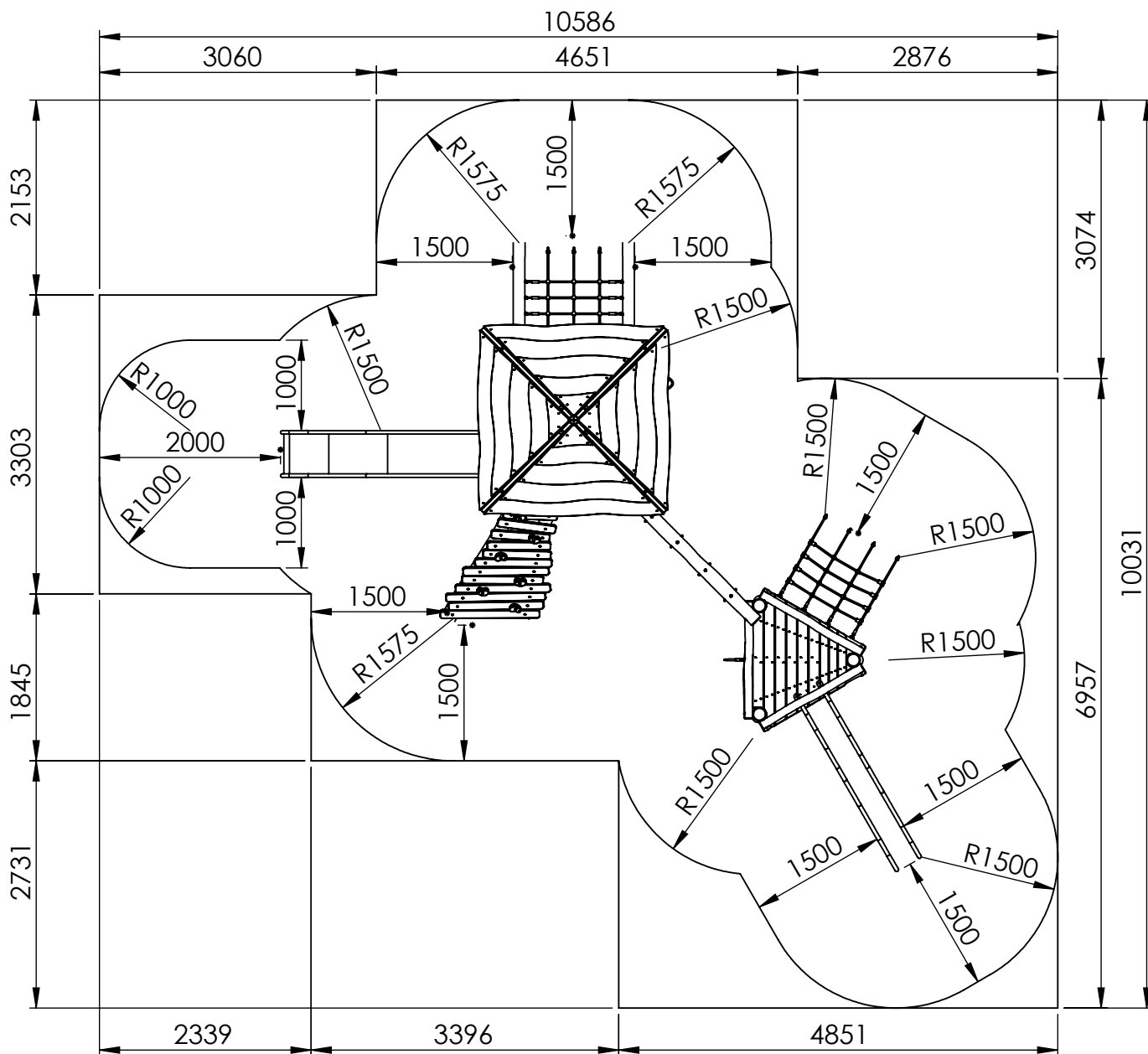

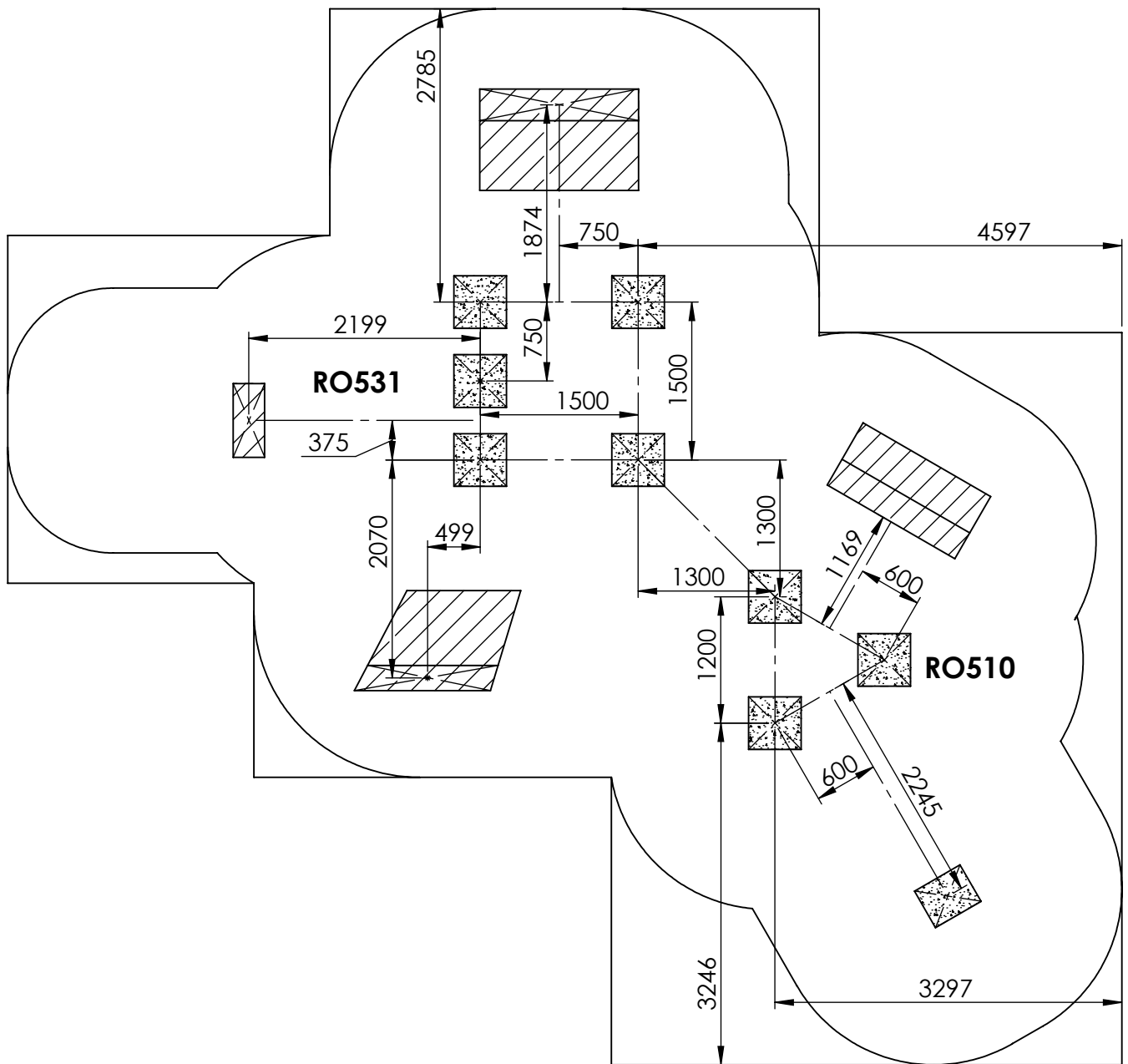

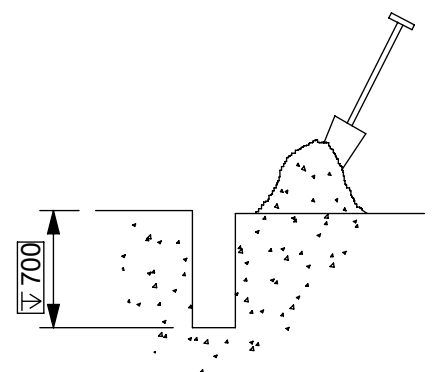
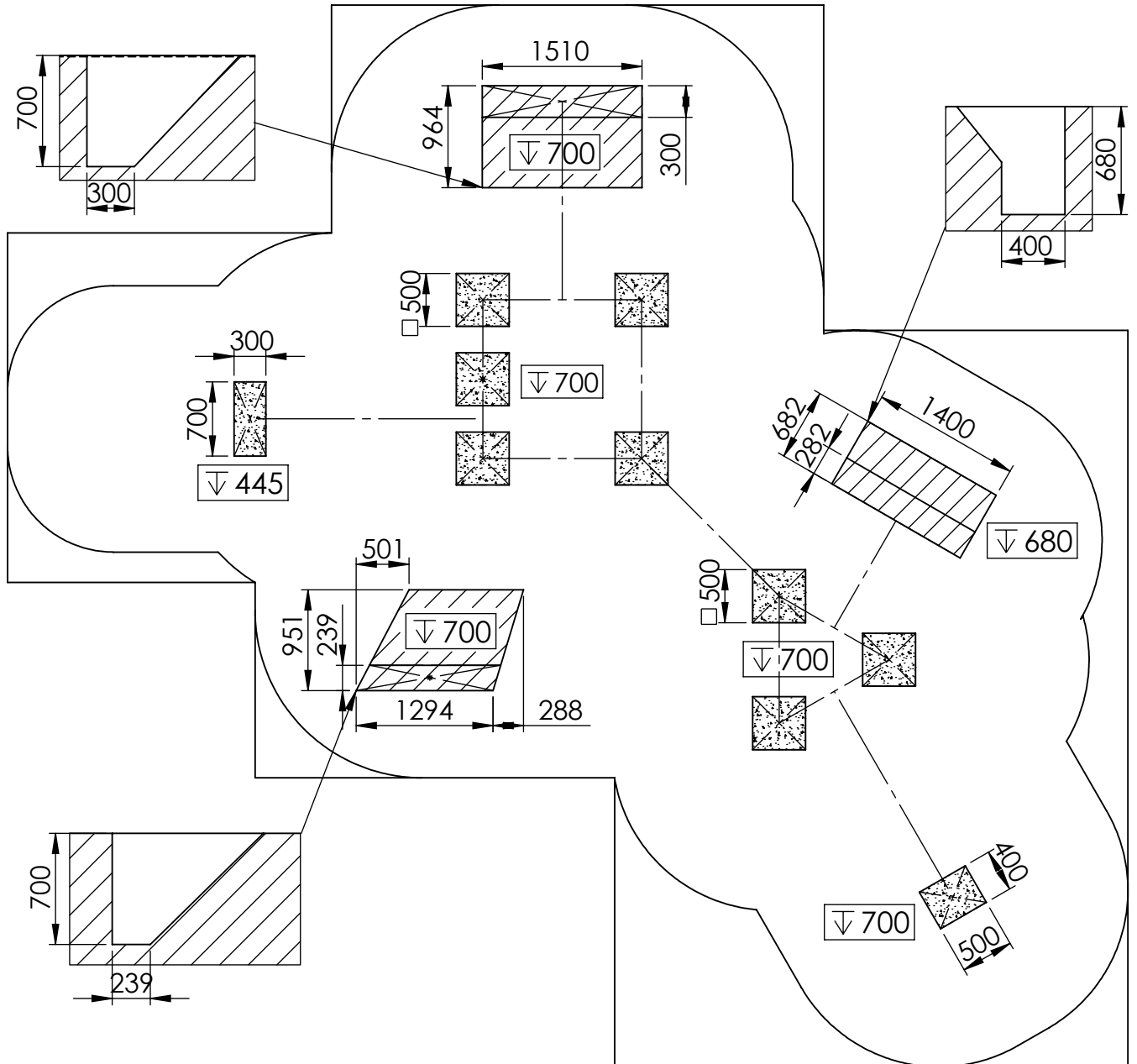

①

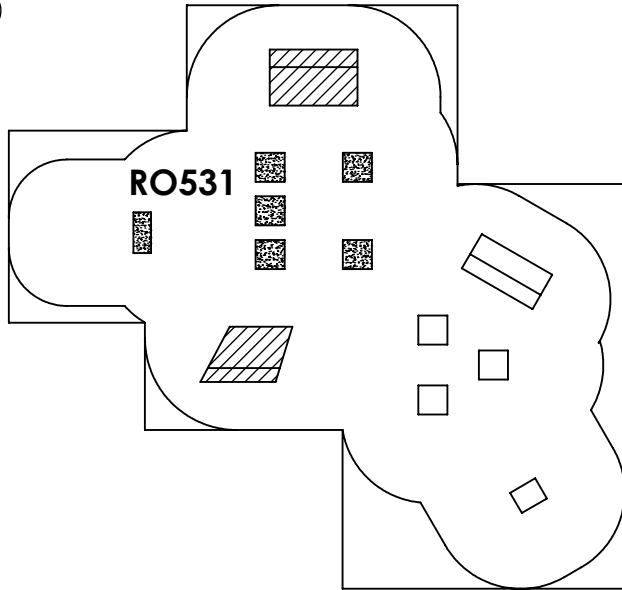

RO531



① → 16 → 17 → 20

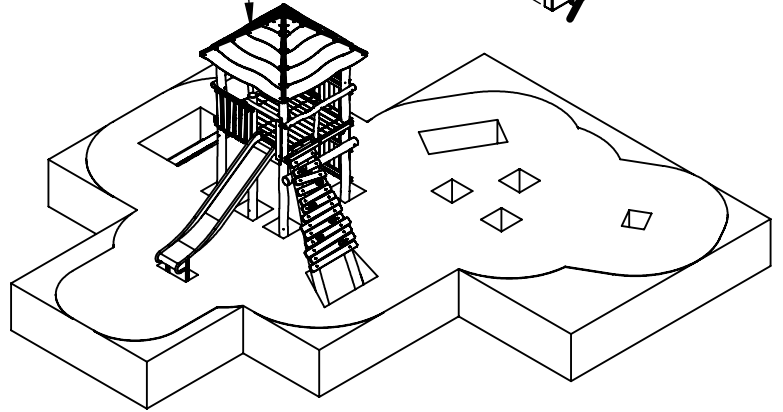
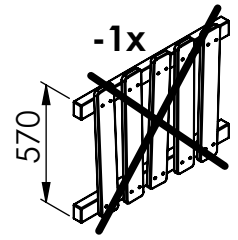

②

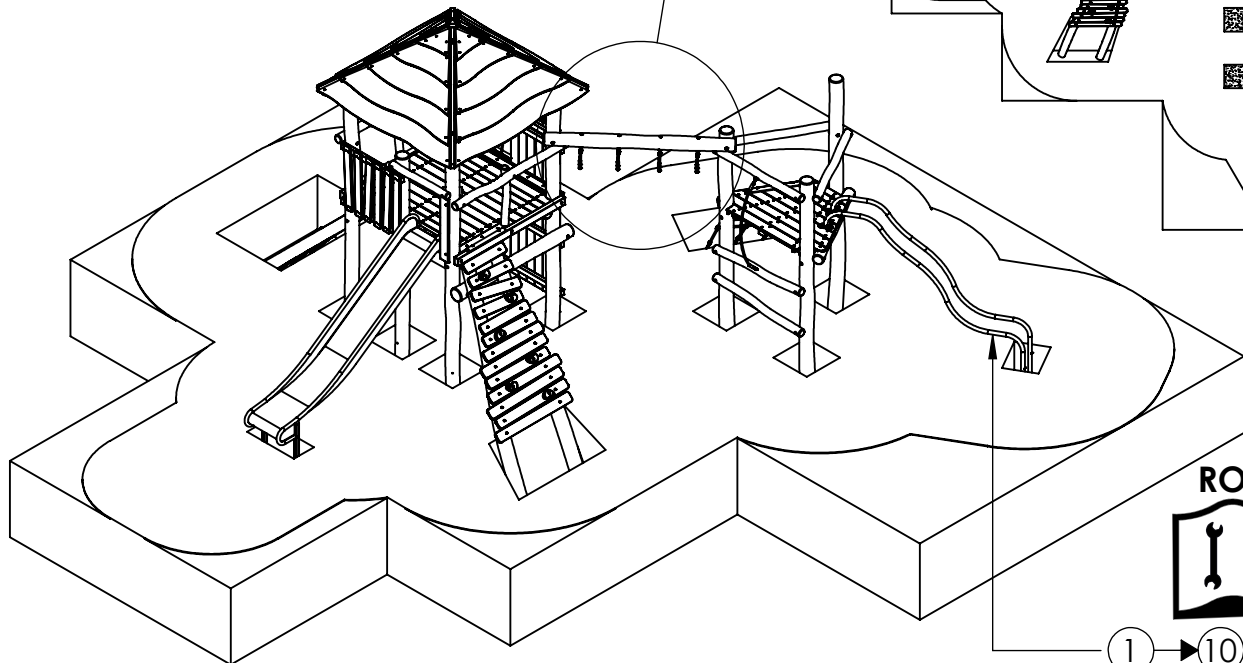
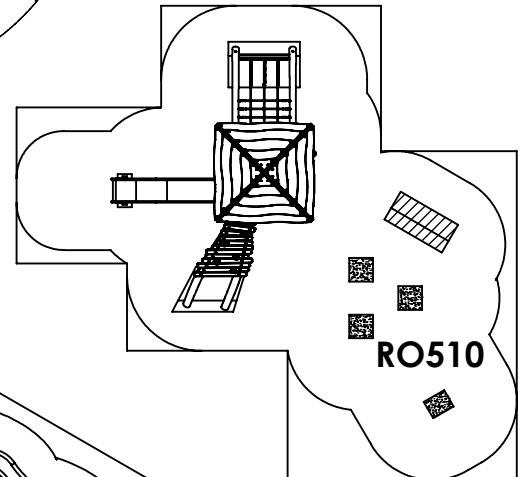
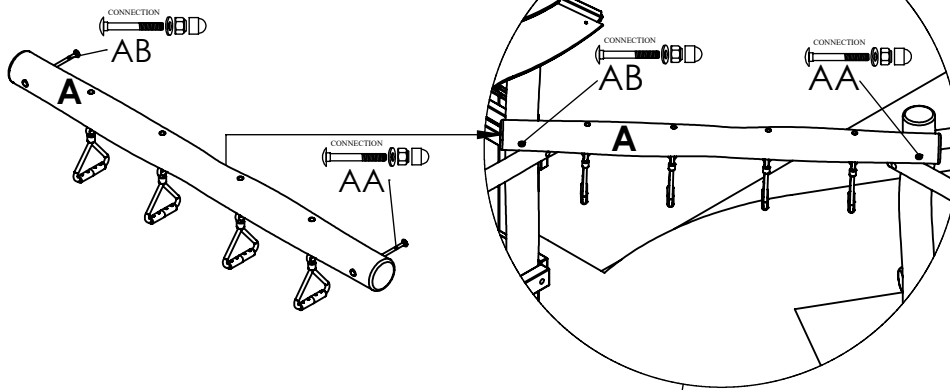

RO510



① → 10 → 11 → 14

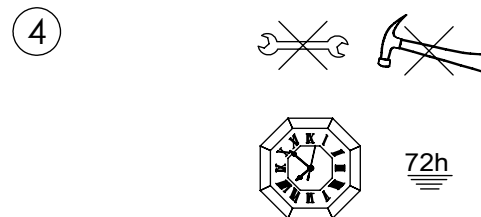
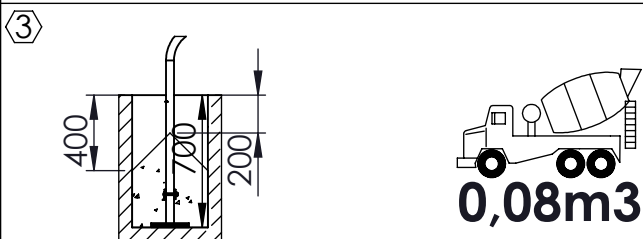
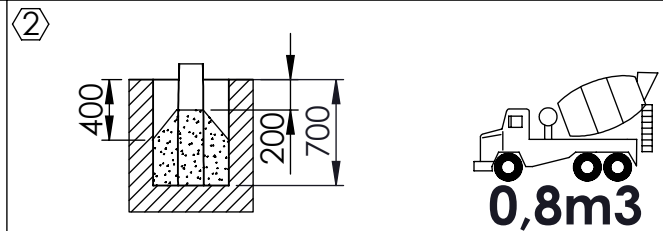
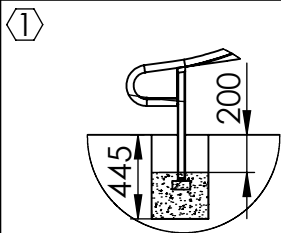
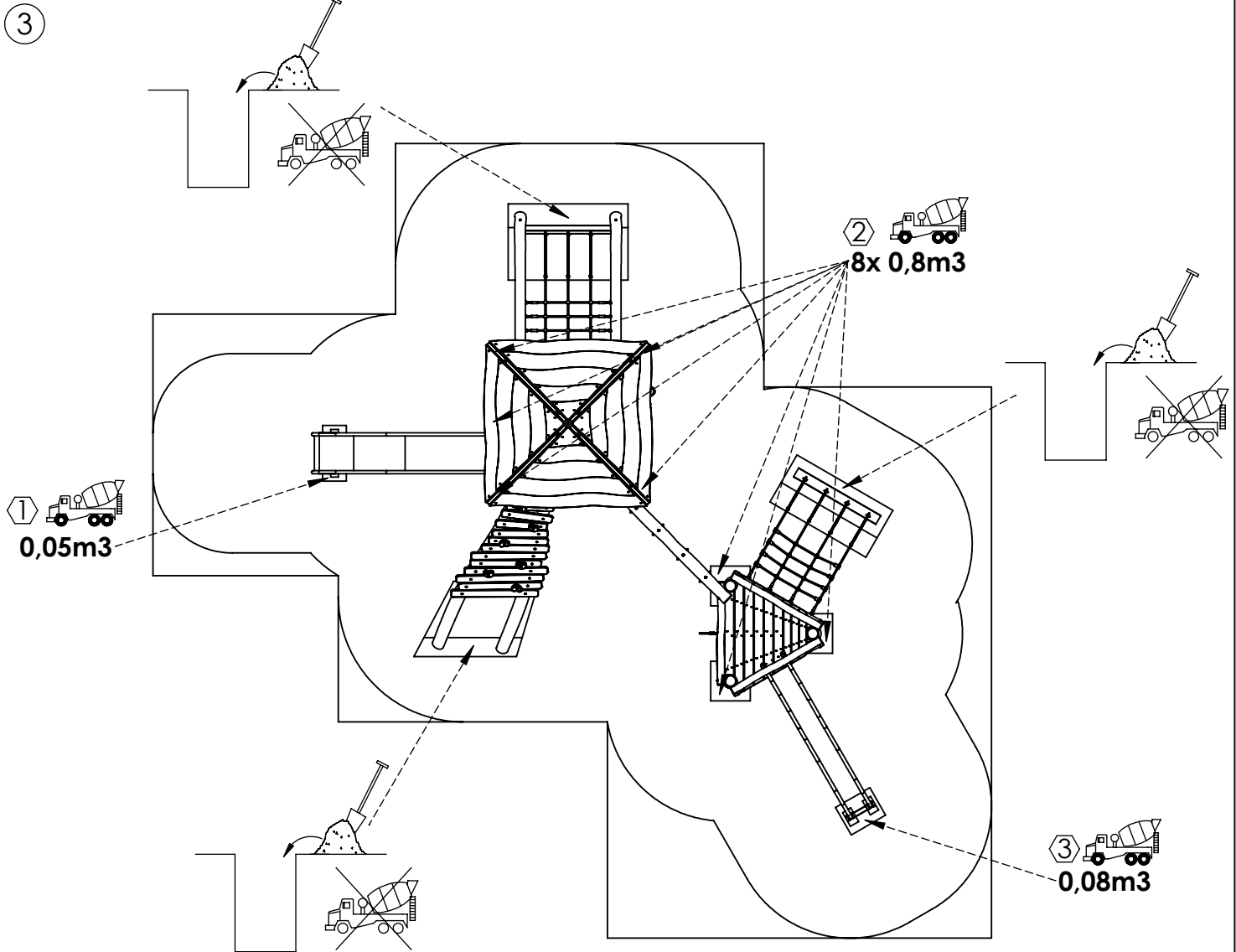

5 Bij droog weer moeten alle bouten en schroeven opnieuw aangespannen worden.
 Par temps sec il faut resserrer régulièrement toute la visserie.
 By dry and warm weather check the tightness of all bolts and screws.
 Bei trockenem Wetter müssen alle Schrauben und Bolzen aufs neue angespannt werden.
 Para el tiempo seco, se necesita cerrar o ajustar los tornillos y tuercas.
 Con tempo asciutto, tutti i bulloni e le viti devono essere avvitate nuovamente.

